

Pavilion O,
by Kettal Studio

kettal

Index

1. Structure & Parts

- Side Panels
- Ceiling
- Side Accessories

2. Acoustic side panels

3. Lighting

4. Accessories

- Monitor
- Wireless system
- Soundbar & Camera
- Room reservation screen
- Safety
- Wall & table mounted outlets

5. Management System

6. Technical data

7. Aesthetics & Materiality

Pavilion O, Structure & Parts

kettal

Overview

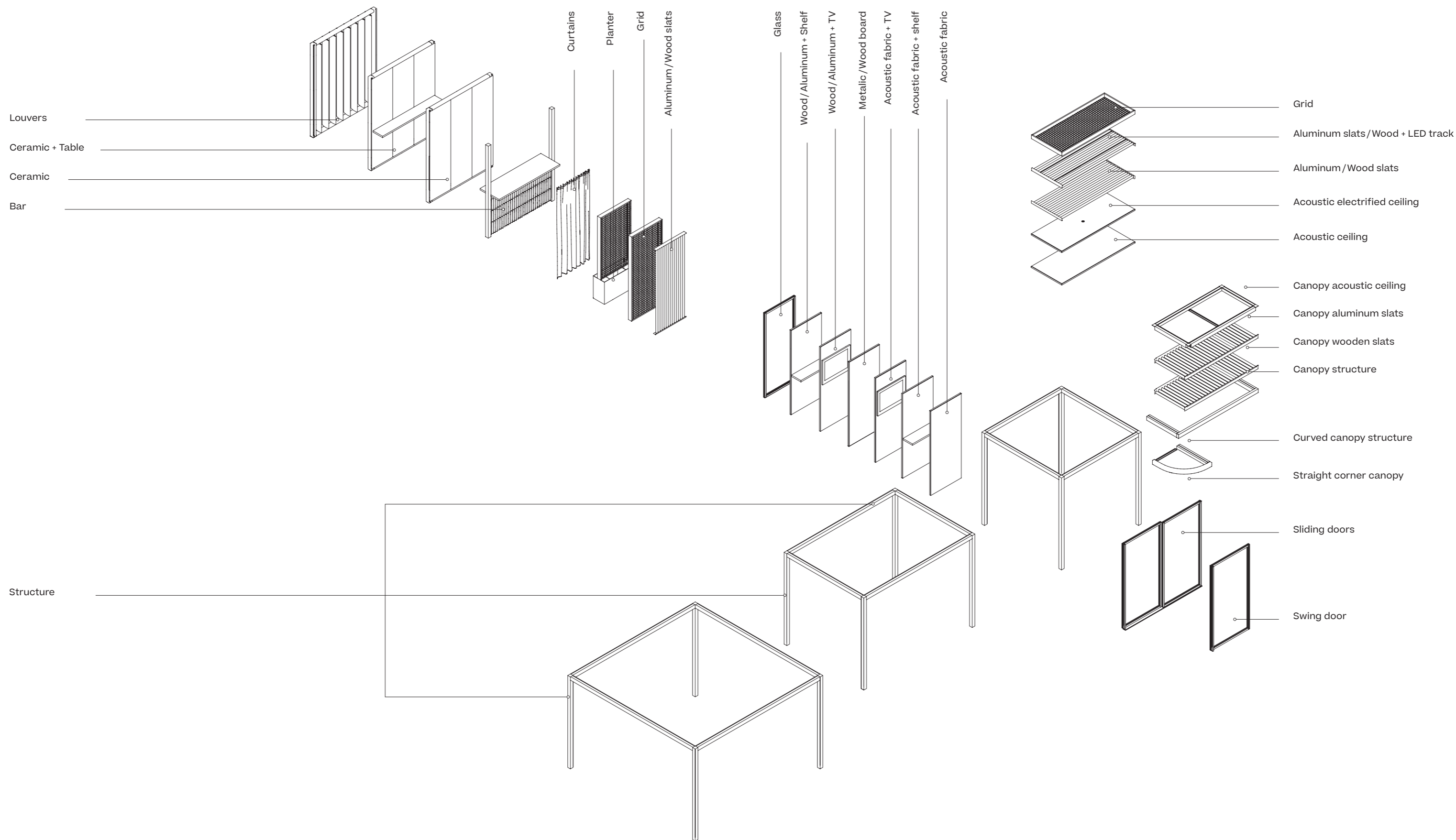

Side panels

Side panels

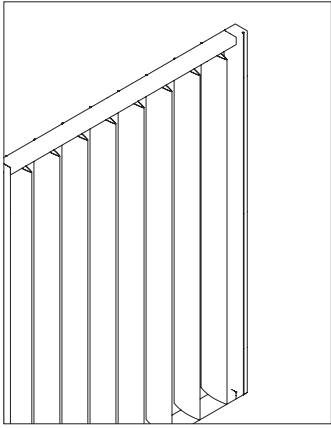

Louvers

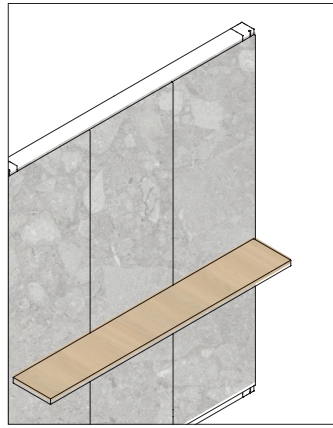

Ceramic + Table



Ceramic

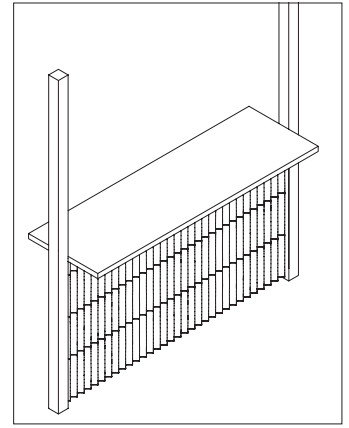

Bar

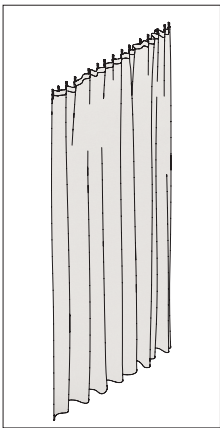

Curtains

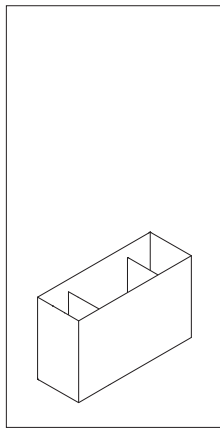

Planter

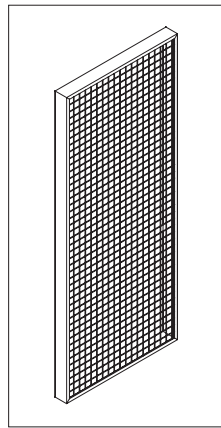

Grid

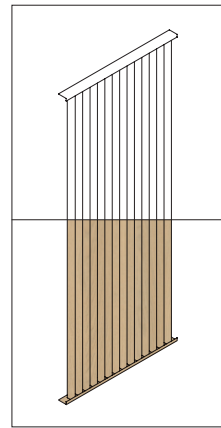

Aluminum/Wooden slats

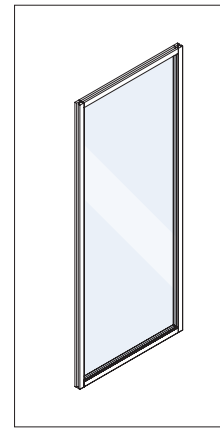

Glass



Acoustic fabric or wood

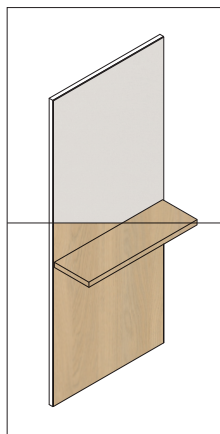

Acoustic fabric or wood with shelf

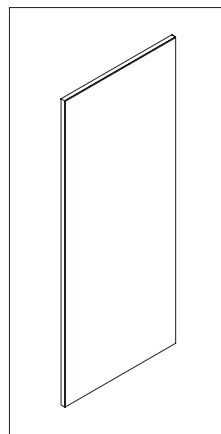

Metallic board

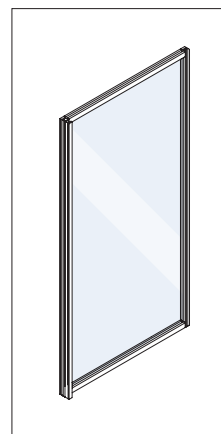

Swing door

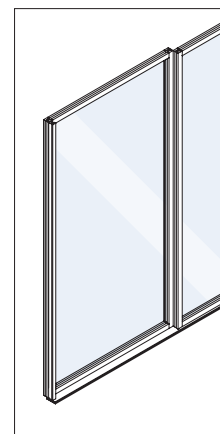

Swing door

Ceiling

Ceiling

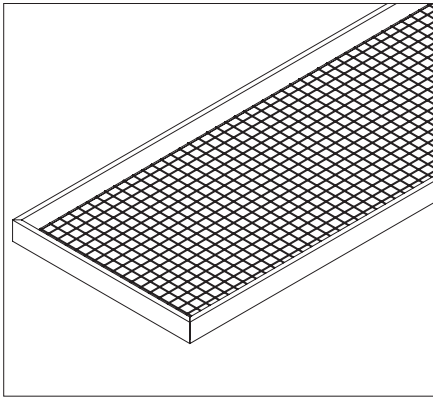

Grid

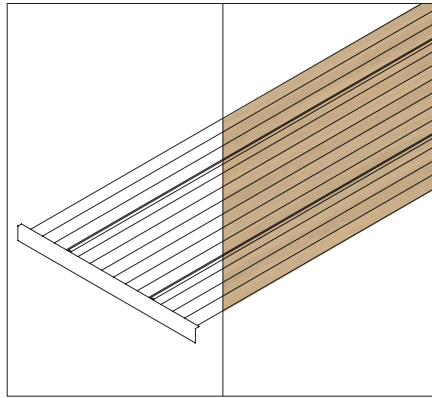

Aluminum or wooden slats with LED track

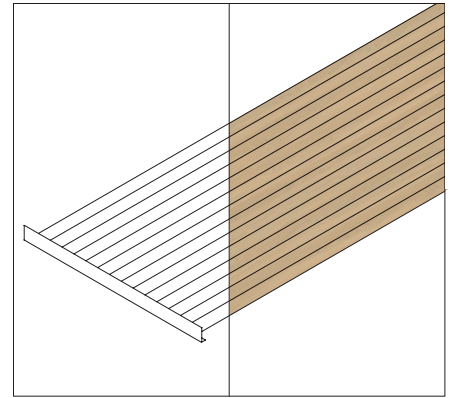

Aluminum or wooden slats

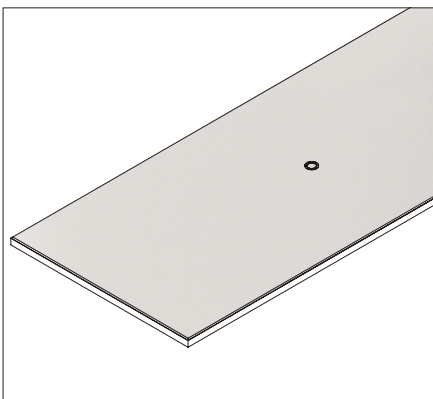

Acoustic electrified ceiling / Acoustic ceiling

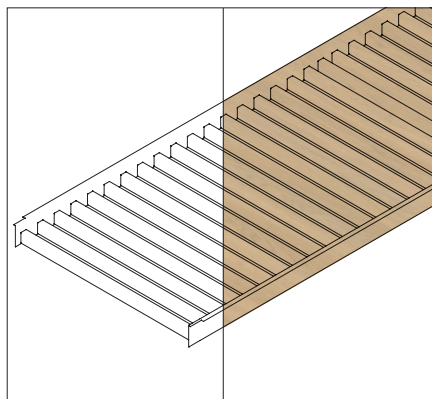

Canopy aluminum slats or wooden slats

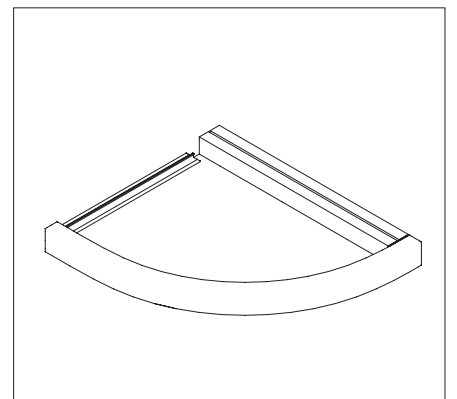

Curved canopy structure

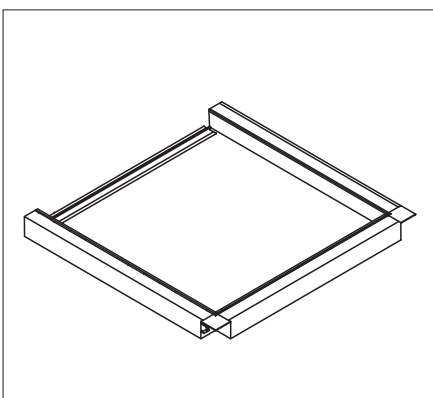

Straight corner canopy

Accessories

Side accessories

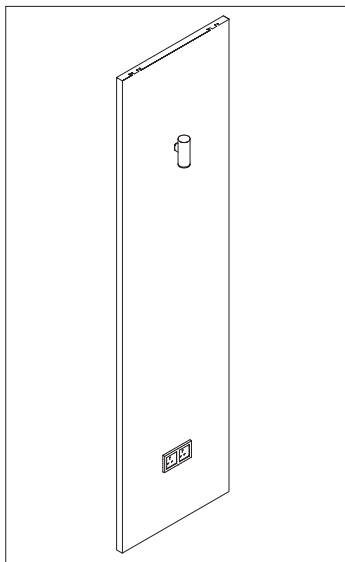

Light and plug

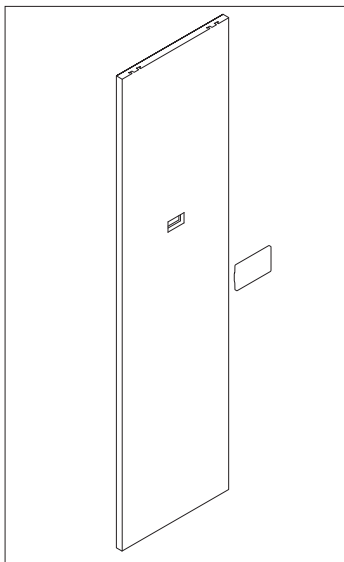

Small display

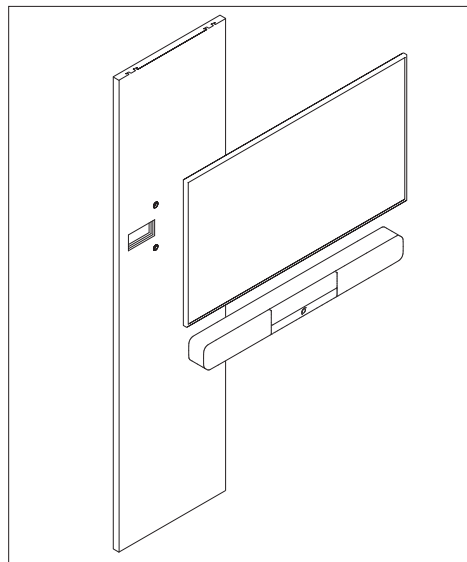

TV

Pavilion O

Acoustic side panels

kettal

Acoustic plus

Description

All our panels are tested to ensure they meet the required acoustic levels. We have tested some of the wall combinations to provide guidelines with regard to acoustic levels. Acoustic performance varies depending on the material selection for each wall.

The O glass version offers excellent acoustic performance, creating a comfortable and efficient working environment. It is based on 6+6 laminates with a soundproofing membrane to provide an impressive acoustic performance of up to 39dB. We also offer a range of solid wall options in fabric and wood. Many of these alternative wall options offer excellent acoustic performance properties. Our laminated panels not only provide additional acoustic performance, but also come in a range of colors. As a result, you can customize your Pavilion O to reflect your brand image or simply to create a bright office space. In addition, the eco-friendly panels reduce and control reverberated noise within the Pavilion, further enhancing the overall soundproofing performance.

Key functions

- All materials meet the standard B-s2, d0.
- Anti memory acoustic foam
- Easy clean material
- Odor free and antimicrobial

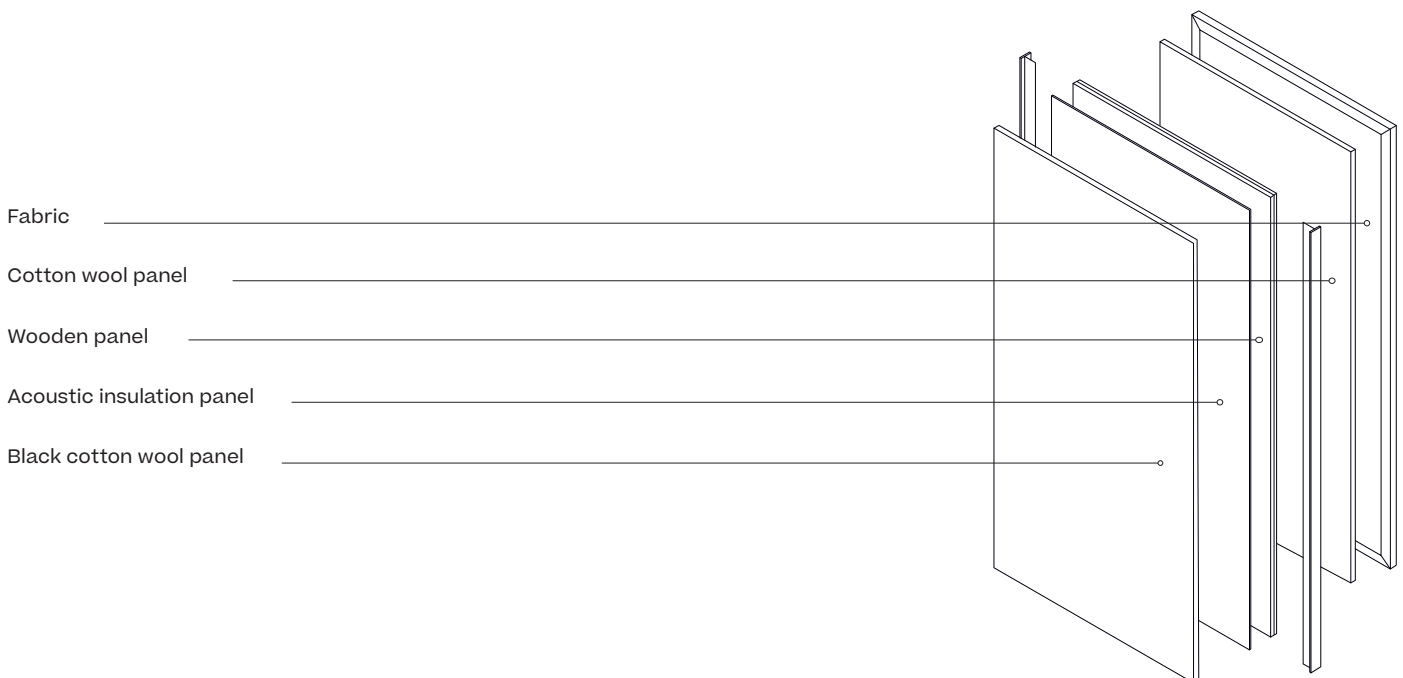

Acoustic plus

Technical specifications



Ceiling Panel

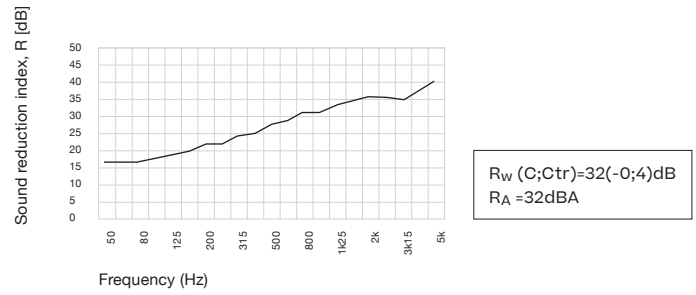

Plus Wall Panel

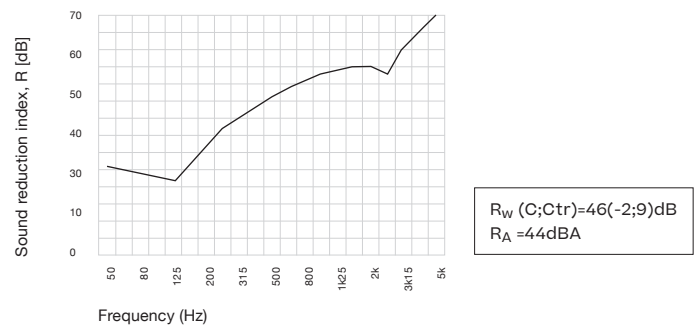

Plus Acoustic Glass & Glass door

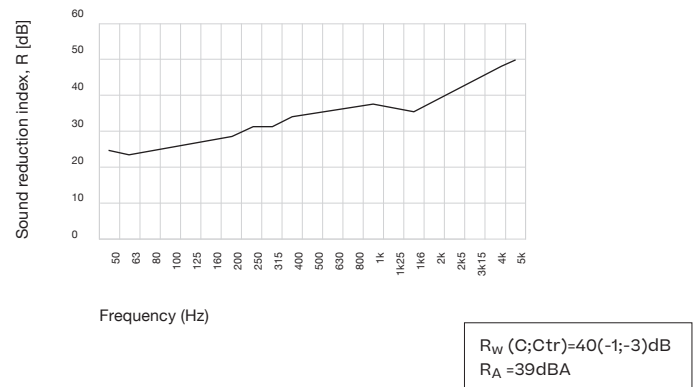

Acoustic comfort

Description

All our panels are tested to ensure they meet the required acoustic levels. We have tested some of the wall combinations to provide guidelines with regard to acoustic levels. Acoustic performance varies depending on the material selection for each wall.

The O glass version offers excellent acoustic performance, creating a comfortable and efficient working environment. It is based on 4+4 laminates with a soundproofing membrane to provide an impressive acoustic performance of up to 35dB. We also offer a range of solid wall options in fabric and wood. Many of these alternative wall options offer excellent acoustic performance properties. Our laminated panels not only provide additional acoustic performance, but also come in a range of colors. As a result, you can customize your Pavilion O to reflect your brand image or simply to create a bright office space. In addition, the eco-friendly panels reduce and control reverberated noise within the Pavilion, further enhancing the overall soundproofing performance.

Key functions

- All materials meet the standard B-s2, d0.
- Anti memory acoustic foam
- Easy clean material
- Odor free and antimicrobial

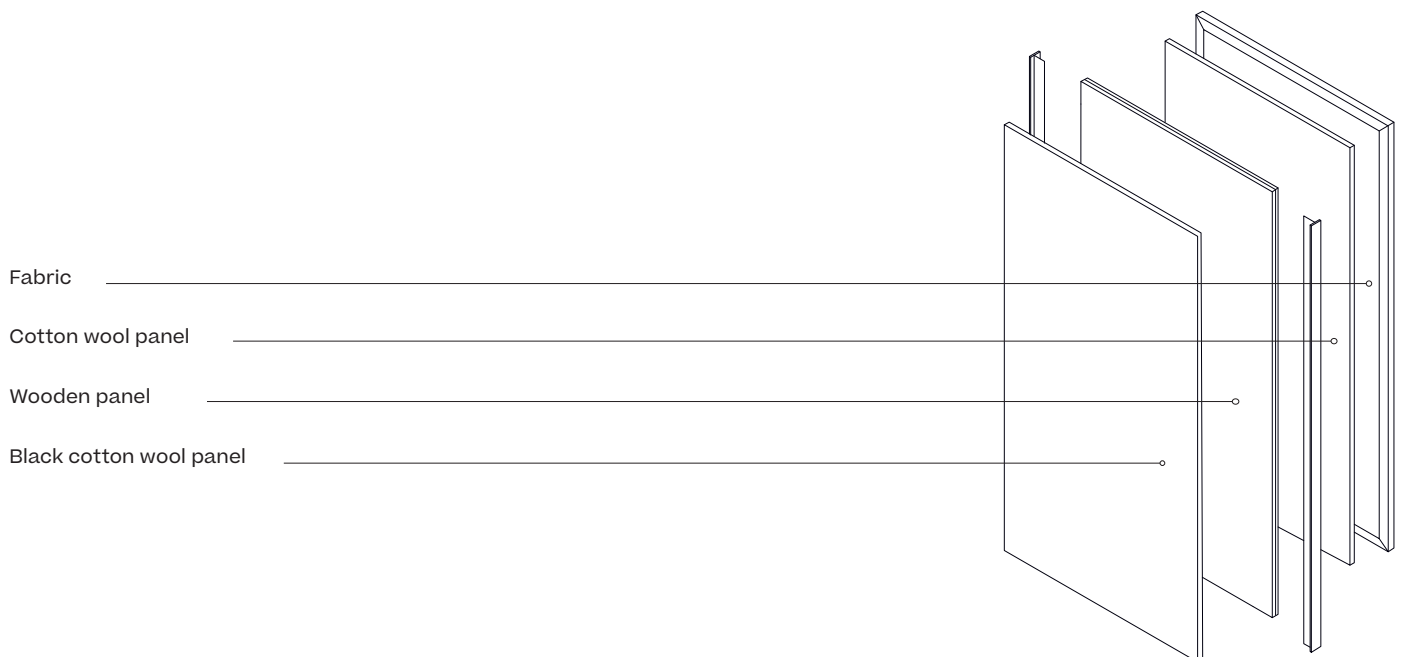

Acoustic comfort

Technical specifications



Ceiling Panel

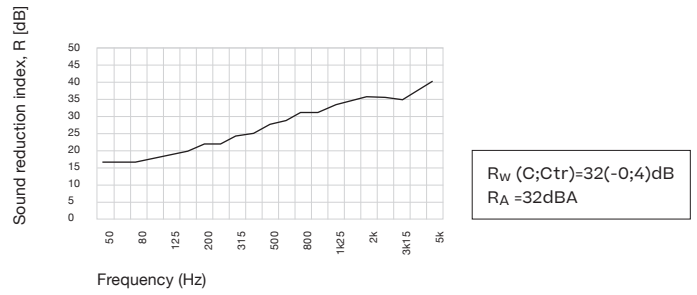

Comfort Wall Panel

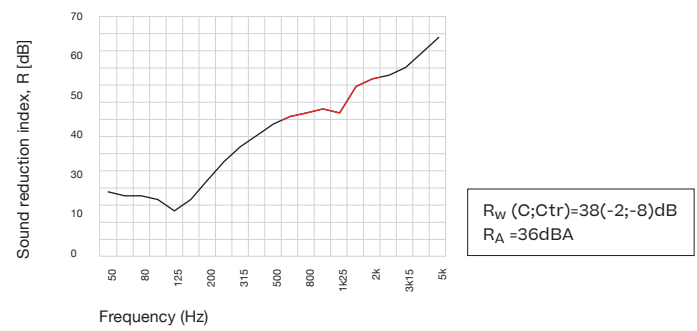

Comfort Acoustic Glass & Glass door

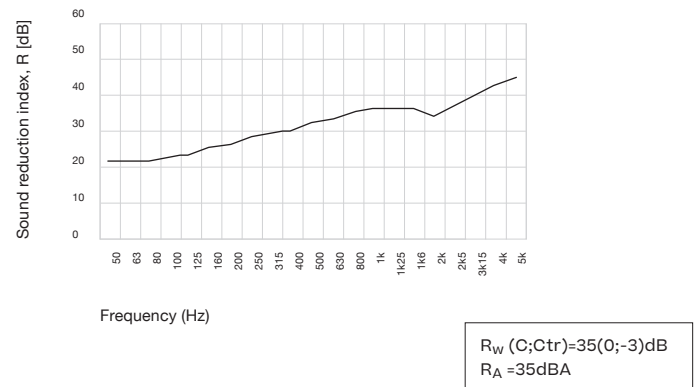

Pavilion O Lighting

kettal

Integrated controlable light range

Integrated LED Stripes



LED Track curtain integrated



LED Track integrated



LED Track slats integrated

Pendant / Wall Curtain

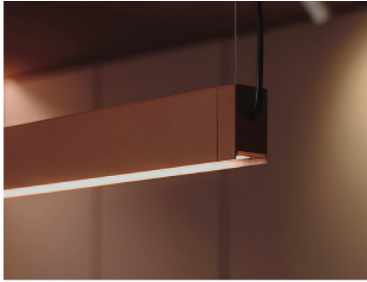

LED Track

Ceiling Lighting



LED Track curtain integrated

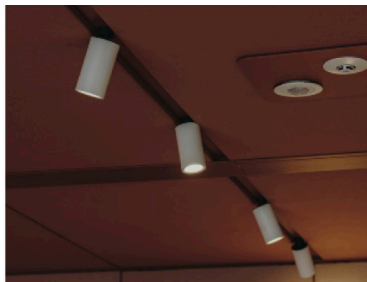

LED Track integrated



LED Track slats integrated

Integrated Decorative Lighting

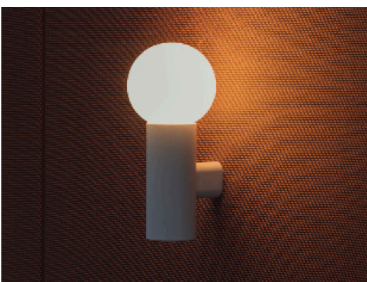

Dots light up

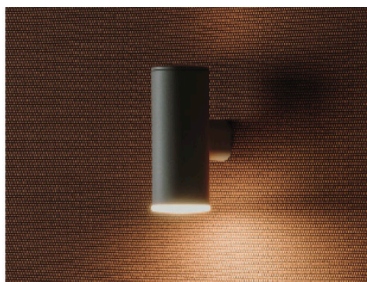

Dots light down

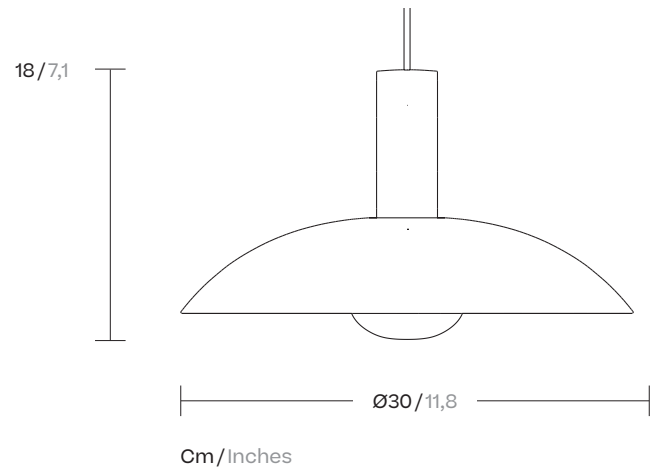

Table Dots lamp (Phonebooths only)

Lighting

Dots pendant open

This suspended light is based on the Dots spotlight system. With its two open and closed diffusers, it directs most of the light downwards. By directing most of the light downwards, the shade is molded to illuminate spaces while protecting peoples' eyes from any direct glare. The matte white interior of the elliptical shade helps create a uniform light that is ideal for both directed and general ambient lighting needs.



Lighting

Dots pendant open

UL 1598 compliance certificate all internal electrical components.

Maintenance

Clean the surface with a damp cotton cloth. Avoid direct contact with solvents and oxides. (text to be agreed)

Technical specifications

| | |
|----------------------------|----------------------------------------------------|
| Codes | KS34-002-00 / KS34-001-00 / etc. |
| Variant | 35 K |
| Maximum power (W) | 8 W |
| Input voltage | 100-240 V ~50/60 Hz |
| Nominal voltage (V) | 24 Vdc |
| Weight (kg) | 1.5 kg/m - 3.3 lbs/m |
| Light source | Integrated power supply |
| No. LEDs | 8 LEDs |
| Protection type (IP) | IP 65 |
| Dimmable | Yes (Kettal provides a ROS integrated homologated) |
| Colour temperature (K) | 3500 K |
| Luminous flux (lm) | 900 lm |
| Luminous efficiency (lm/W) | 115 lm/w |
| CRI | 90 CRI |
| Service life (h) | IES TM21 L70 > 50,000 h |
| Applicable standards | UNE-EN 60598 / UNE-EN 55015 / UNE-EN 60529 |
| Material | Aluminium / PMMA |
| Packaging (unit/volume) | 1 u box (0.1 m ³ / 2.2 cu ft) |
| Energy efficiency class | A++ |
| Power factor | 0.90 |
| Cable length | 5 m |
| Indoor/outdoor use | Suitable for indoor and outdoor use |
| Guarantee | 2 years |

Lighting

Dots pendant closed

This suspended light is based on the Dots spotlight system. With its two open and closed diffusers, it directs most of the light downwards. By directing most of the light downwards, the shade is molded to illuminate spaces while protecting peoples' eyes from any direct glare. The matte white interior of the elliptical shade helps create a uniform light that is ideal for both directed and general ambient lighting needs.

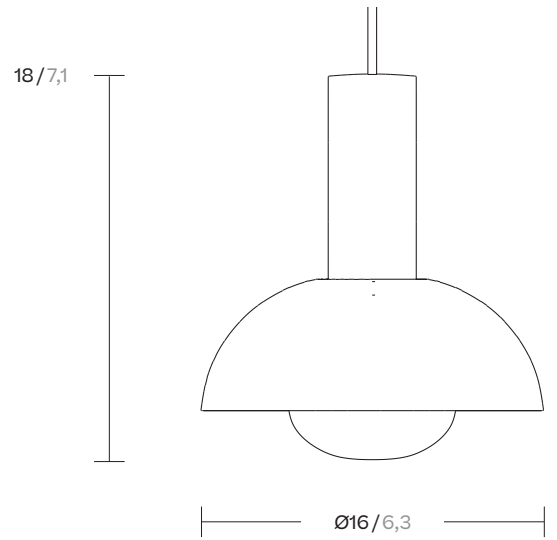

Cm/Inches



Lighting

Dots pendant closed

UL 1598 compliance certificate all internal electrical components.

Maintenance

Clean the surface with a damp cotton cloth. Avoid direct contact with solvents and oxides. (text to be agreed)

Technical specifications

| | |
|----------------------------|----------------------------------------------------|
| Codes | KS34-002-00 / KS34-001-00 / etc. |
| Variant | 35 K |
| Maximum power (W) | 8 W |
| Input voltage | 100-240 V ~50/60 Hz |
| Nominal voltage (V) | 24 Vdc |
| Weight (kg) | 1.5 kg/m - 3.3 lbs/m |
| Light source | Integrated power supply |
| No. LEDs | 8 LEDs |
| Protection type (IP) | IP 65 |
| Dimmable | Yes (Kettal provides a ROS integrated homologated) |
| Colour temperature (K) | 3500 K |
| Luminous flux (lm) | 900 lm |
| Luminous efficiency (lm/W) | 115 lm/w |
| CRI | 90 CRI |
| Service life (h) | IES TM21 L70 > 50,000 h |
| Applicable standards | UNE-EN 60598 / UNE-EN 55015 / UNE-EN 60529 |
| Material | Aluminium / PMMA |
| Packaging (unit/volume) | 1 u box (0.1 m ³ / 2.2 cu ft) |
| Energy efficiency class | A++ |
| Power factor | 0.90 |
| Cable length | 5 m |
| Indoor/outdoor use | Suitable for indoor and outdoor use |
| Guarantee | 2 years |

Lighting

Pendant LED Track

This system consists of a bar that combines direct or indirect light, suspended by two coaxial cables that provide support and the electrical wiring. Perfect for offices that require excellent light efficiency and visual comfort.

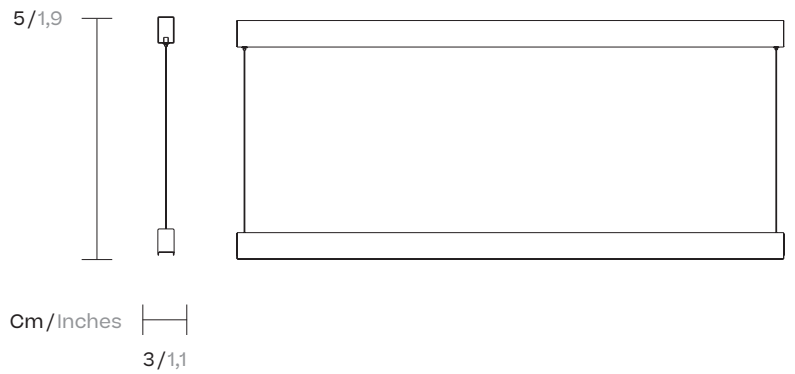
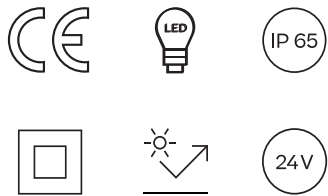

Lighting

Dots light ball up

The Dots wall luminaires feature LED light sources and project light above or below the horizontal plane for an authentic washlighting effect, ideal for selectively illuminating corners, specific spaces, facility corridors, as well as walkways, access routes, signs and so on.

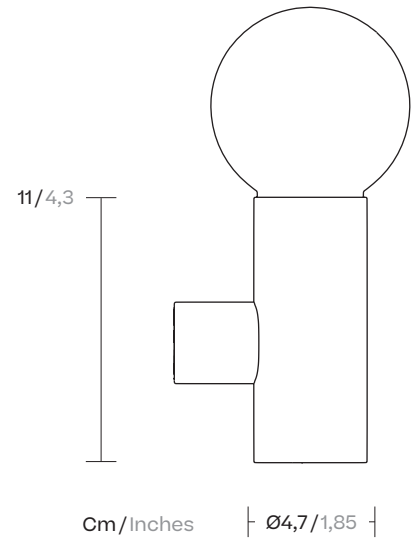
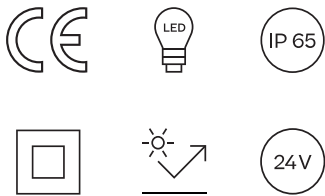

Lighting

Dots light ball up

UL 1598 compliance certificate all internal electrical components.

Maintenance

Clean the surface with a damp cotton cloth. Avoid direct contact with solvents and oxides. (text to be agreed)

Technical specifications

| | |
|----------------------------|----------------------------------------------------|
| Codes | KS34-006-00 / KS34-003-00 / etc. |
| Variant | 35 K |
| Maximum power (W) | 5 W |
| Input voltage | 100-240 V ~50/60 Hz |
| Nominal voltage (V) | 24 Vdc |
| Weight (kg) | 1.5 kg/m - 3.3 lbs/m |
| Light source | Integrated power supply |
| No. LEDs | 14 LEDs |
| Protection type (IP) | IP 65 |
| Dimmable | Yes (Kettal provides a ROS integrated homologated) |
| Colour temperature (K) | 3500 K |
| Luminous flux (lm) | 650 lm |
| Luminous efficiency (lm/W) | 98 lm/w |
| CRI | 90 CRI |
| Service life (h) | IES TM21 L70 > 50,000 h |
| Applicable standards | UNE-EN 60598 / UNE-EN 55015 / UNE-EN 60529 |
| Material | Aluminium / PMMA |
| Packaging (unit/volume) | 1 u box (0.1 m ³ / 2.2 cu ft) |
| Energy efficiency class | A++ |
| Power factor | 0.90 |
| Cable length | 5 m |
| Indoor/outdoor use | Suitable for indoor and outdoor use |
| Guarantee | 2 years |

Lighting

Dots light down / up & down

The Dots wall luminaires feature LED light sources and project light above or below the horizontal plane for an authentic washlighting effect, ideal for selectively illuminating corners, specific spaces, facility corridors, as well as walkways, access routes, signs and so on.



11/4,3

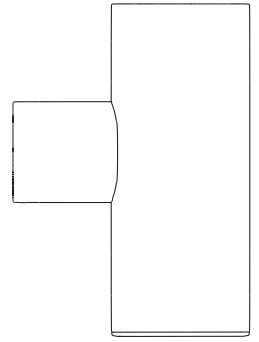

Cm/Inches

∅4,7/1,85



Lighting

Dots light down / up & down

UL 1598 compliance certificate all internal electrical components.

Maintenance

Clean the surface with a damp cotton cloth. Avoid direct contact with solvents and oxides. (text to be agreed)

Technical specifications

| | |
|----------------------------|----------------------------------------------------|
| Codes | KS34-006-00 / KS34-003-00 / etc. |
| Variant | 35 K |
| Maximum power (W) | 5 W |
| Input voltage | 100-240 V ~50/60 Hz |
| Nominal voltage (V) | 24 Vdc |
| Weight (kg) | 1.5 kg/m - 3.3 lbs/m |
| Light source | Integrated power supply |
| No. LEDs | 14 LEDs |
| Protection type (IP) | IP 65 |
| Dimmable | Yes (Kettal provides a ROS integrated homologated) |
| Colour temperature (K) | 3500 K |
| Luminous flux (lm) | 650 lm |
| Luminous efficiency (lm/W) | 98 lm/w |
| CRI | 90 CRI |
| Service life (h) | IES TM21 L70 > 50,000 h |
| Applicable standards | UNE-EN 60598 / UNE-EN 55015 / UNE-EN 60529 |
| Material | Aluminium / PMMA |
| Packaging (unit/volume) | 1 u box (0.1 m ³ / 2.2 cu ft) |
| Energy efficiency class | A++ |
| Power factor | 0.90 |
| Cable length | 5 m |
| Indoor/outdoor use | Suitable for indoor and outdoor use |
| Guarantee | 2 years |

Lighting

Articulated LED Track

Our surface-mounted range that uses an LED light source. This system is composed of linear LED strips mounted on aluminum extrusion micro-profiles of varying lengths. These light modules are combined with adjustable 360° Dots spotlights that are available with different beam optics.

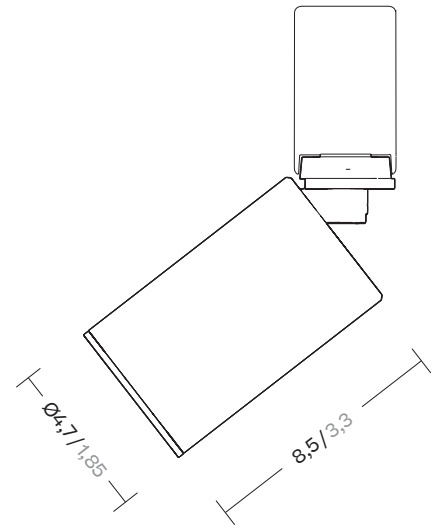
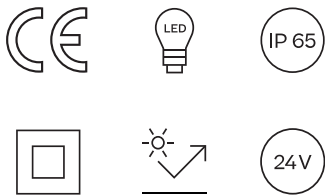

Cm/Inches



Lighting

Articulated LED Track

UL 1598 compliance certificate all internal electrical components.

Maintenance

Clean the surface with a damp cotton cloth. Avoid direct contact with solvents and oxides. (text to be agreed)

Technical specifications

| | |
|----------------------------|----------------------------------------------------|
| Codes | A3DIL-TO2-10 / A3DIT-TO2-10 / etc. |
| Variant | 35 K |
| Maximum power (W) | 8 W/u |
| Input voltage | 100-240 V ~50/60 Hz |
| Nominal voltage (V) | 24 Vdc |
| Weight (kg) | 2.5 kg/m - 5.5 lbs/m |
| Light source | Integrated power supply |
| No. LEDs | 8 LEDs |
| Protection type (IP) | IP 65 |
| Dimmable | Yes (Kettal provides a ROS integrated homologated) |
| Colour temperature (K) | 3500 K |
| Luminous flux (lm) | 900 lm |
| Luminous efficiency (lm/W) | 115 lm/w |
| CRI | 90 CRI |
| Service life (h) | IES TM21 L70 > 50,000 h |
| Applicable standards | UNE-EN 60598 / UNE-EN 55015 / UNE-EN 60529 |
| Material | Aluminium / PMMA |
| Packaging (unit/volume) | 1 u box (0.1 m ³ / 2.2 cu ft) |
| Energy efficiency class | A++ |
| Power factor | 0.90 |
| Cable length | 1 m |
| Indoor/outdoor use | Suitable for indoor and outdoor use |
| Guarantee | 2 years |

Lighting

Integrated LED Track

An integrated LED lighting system that offers solutions suited to any type of installation. It provides pleasant and efficient visual comfort, combined with high-quality performance and aesthetics.



4,7/1,8 



Cm/Inches



Lighting

Integrated LED Track

UL 1598 compliance certificate all internal electrical components.

Maintenance

Clean the surface with a damp cotton cloth. Avoid direct contact with solvents and oxides. (text to be agreed)

Technical specifications

| | |
|----------------------------|----------------------------------------------------|
| Codes | A3CIL-TO2-10 / A3CIT-TO2-10 / etc. |
| Variant | 35 K |
| Maximum power (W) | 22 W/m |
| Input voltage | 100-240 V ~50/60 Hz |
| Nominal voltage (V) | 24 Vdc |
| Weight (kg) | 2.5 kg/m - 5.5 lbs/m |
| Light source | Integrated power supply |
| No. LEDs | 240 LEDs/m |
| Protection type (IP) | IP 65 |
| Dimmable | Yes (Kettal provides a ROS integrated homologated) |
| Colour temperature (K) | 3500 K |
| Luminous flux (lm) | 2800 lm/m |
| Luminous efficiency (lm/W) | 136 lm/w |
| CRI | 90 CRI |
| Service life (h) | IES TM21 L70 > 50,000 h |
| Applicable standards | UNE-EN 60598 / UNE-EN 55015 / UNE-EN 60529 |
| Material | Aluminium / PMMA |
| Packaging (unit/volume) | 1 u box (0.1 m ³ / 2.2 cu ft) |
| Energy efficiency class | A++ |
| Power factor | 0.90 |
| Cable length | 1 m |
| Indoor/outdoor use | Suitable for indoor and outdoor use |
| Guarantee | 2 years |

Lighting

Curtain LED Track

A recessed lighting system equipped with an LED light source. Specially designed for wall-washer lighting, the LED Curtain incorporates lenses to provide optimum light distribution. The LED Curtain range is available in different lengths which means it can be adjusted to suit any space, while its compact size facilitates simple integration within the Pavilion O system.



4,7/1,8



Cm/Inches



Lighting

Microdots

A recessed lighting system in crossbars or aluminium slats. Indoor and outdoor use. Aluminium body. Dimmable bioclimatic ceiling lighting.



Cm/Inches

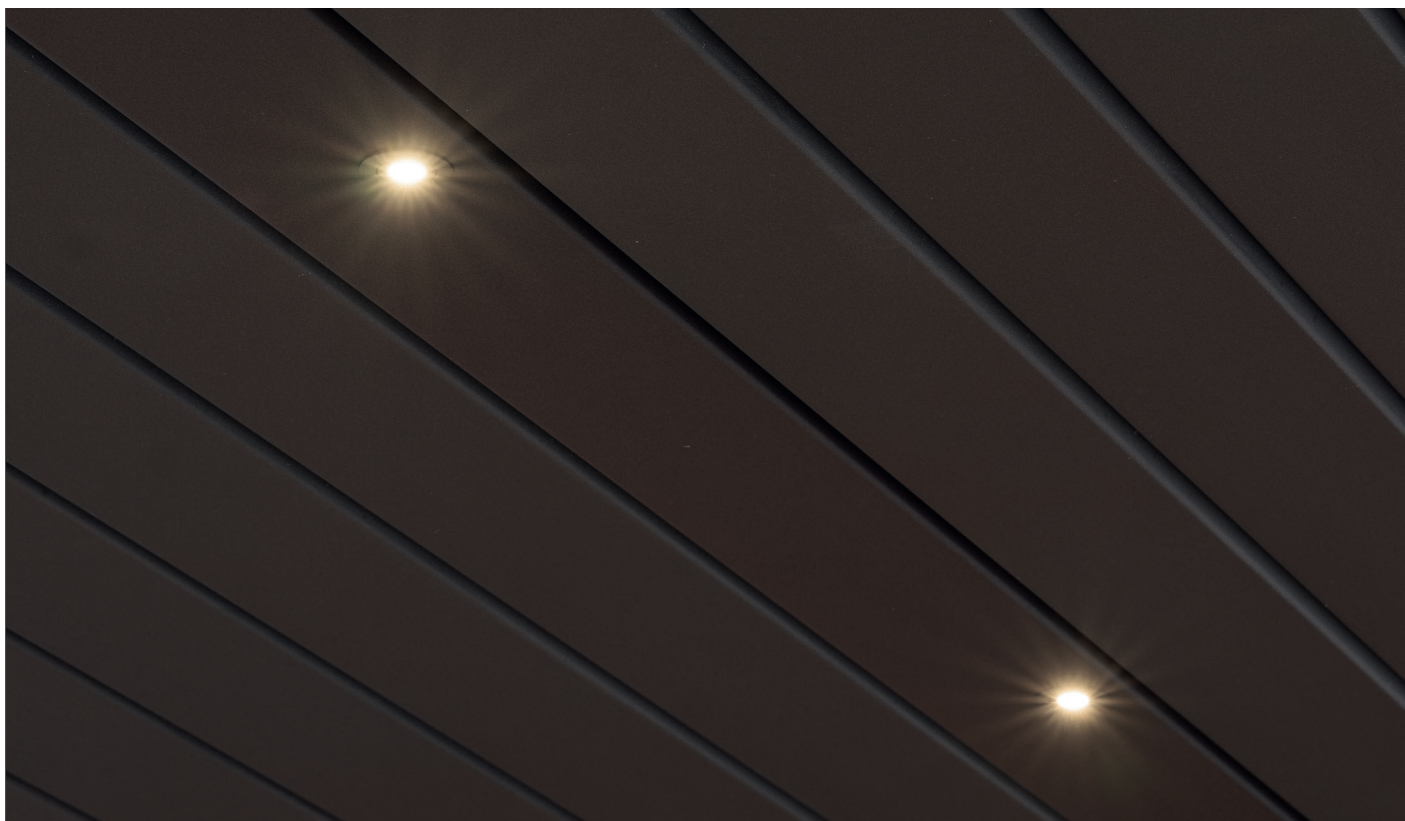
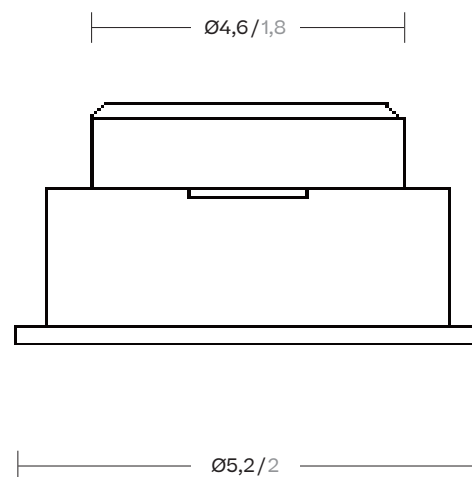

Pavilion O Accessories

kettal

Monitor

Key functions & features

- Samsung monitor
- Slim video monitor
- Plug & Play system
- 3 different Sizes
- Incredible 4K picture quality
- Intelligent UHD upscaling
- Dynamic crystal color
- Clean cable management
- Wi-Fi and Bluetooth built-in

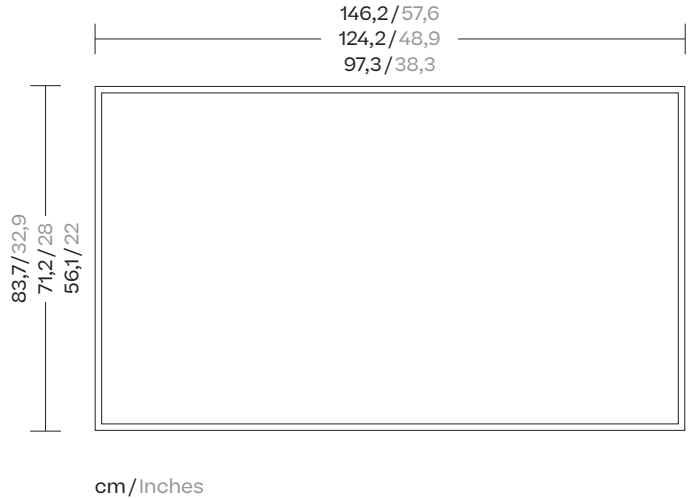

Technical Specifications - Monitor

| Model | ME651 | ME551 | ME431 |
|--------------|--------------------------|--------------------------|--------------------------|
| Type | LCD 651 | LCD 551 | LCD 431 |
| Technology | IPS direct LED backlight | IPS direct LED backlight | IPS direct LED backlight |
| Resolution | UHD (3840 x 2160) | UHD (3840 x 2160) | UHD (3840 x 2160) |
| Power Supply | 100-240 V AC | 100-240 V AC | 100-240 V AC |

Clickshare CX-20

Small room wireless presentation and conference system for PC / MAC or mobile devices.

It allows you to make presentations and use the room camera remotely.

It allows an easy, efficient and continuous user experience.

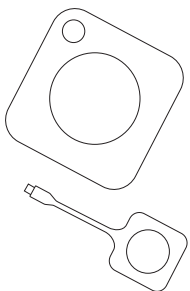

Clickshare CX-20 device

Technical Specifications - Clickshare CX-20

| | |
|-------------------|------------------------------------------------------------------------------------------------------------------------------------------|
| Power Supply | 110/220 V AC Standard |
| Power Consumption | Max. 24 W |
| OS | Windows 8/8.1/10. macOS 10.13 and later updates. Android v9 and later updates (ClickShare app) iOS 12 and later updates (ClickShare app) |
| Video Output | 4K UHD (3840x2160), 30 Hz. HDMI 1.4b |
| Audio Output | USB, HDMI |
| Native protocols | Airplay, Google Cast, Miracast |
| Reach | Max. 30m (100 ft) |
| Certifications | FCC / CE |
| Net Conexion | LAN and WiFi |

Wireless system

Clickshare C-5

Small room wireless presentation and conference system for PC / MAC or mobile devices.

It allows an easy, efficient and continuous user experience.

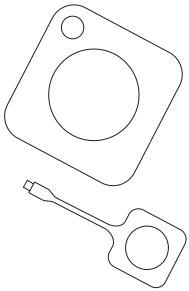

Clickshare C-5 device

Technical Specifications - Clickshare C-5

| | |
|-------------------|------------------------------------------------------------------------------------------------------------------------------------------|
| Power Supply | 110/220 V AC Standard |
| Power Consumption | Max. 24 W |
| OS | Windows 8/8.1/10. macOS 10.13 and later updates. Android v9 and later updates (ClickShare app) iOS 12 and later updates (ClickShare app) |
| Video Output | 4K UHD (3840x2160), 30 Hz. HDMI 1.4b |
| Audio Output | USB, HDMI |
| Native protocols | Airplay, Google Cast, Miracast |
| Reach | Max. 30m (100 ft) |
| Certifications | FCC / CE |
| Net Conexion | LAN and WiFi |

Soundbar & camera

Creston bar

- 4K camera with 150° viewing
- Intelligent HD Camera - Digital autozoom intelligently detects the people in the room and frames them perfectly for an optimal view
- Surrounding audiosystem
- Full set of configurable
- Plug & Play - compatible with major computer OS platforms running any web conferencing software

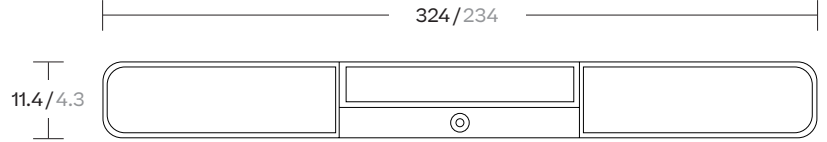

Technical Specifications

| | |
|----------------------------|---------------------------------------------------------------------|
| Camera model | Huddly HQ (mounted internally) |
| Image Sensor | 12 megapixel Sony® IMX477 Type 1/2.3 CMOS sensor |
| Lens | High precision, ultra wide angle, six element aspherical glass lens |
| Field of View | 150° diagonal 120° horizontal 90° vertical |
| Aperture | f/2.8 |
| Processor | Intel® Movidius® Myriad® X VPU |
| Pan/Tilt/Zoom | 3x |
| Autozoom | Yes |
| Dynamic Light Optimization | Auto-adjust light levels and white balance |
| Noise reduction | 3D noise reduction |
| Scalling | Real-time scalling |
| People Counting | Yes |
| Video Output Resolution | HD 1080p at 30fps |
| Main Power | 100-240 VAC, 50/60 Hz |
| Power Consumption | 22W |
| Weight | 15 lb (6.8 kg) |

Compliance

C, IC, UL 62368-1, CSA C22.2 62368-1, EN 62368-1, IEC 62368-1, FCC Part 15 Class B, ICES-003 Issue 5 Class B, EN55022:2010 Class B, AS/NZS CISPR22:2010 Class B, AS/NZS CISPR 22:2010 Class B, EN55024:2010, EN1000-3.2:2014, EN61000-3-3:2013, RoHS compliant

Room reservation screen

Key functions

- Booking management through Touch Screen
- Room reservation linked to your Calendar
- Management through third-party Cloud solution
- Room booking management from email

Installation: Installation can only be performed on a 7" screen acoustic or wood panel.

Wiring: The equipment is supplied by a POE RJ45 network cable provided by Kettal.

Settings: The control screen requires prior programming by Kettal to customise the screen with the client's data and link operation with the company's (client) calendar system. Screen installation is subject to the data provided by the client.

Mail systems allowed



Cloud solutions



Secure endpoint



Cloud solution



Calendar

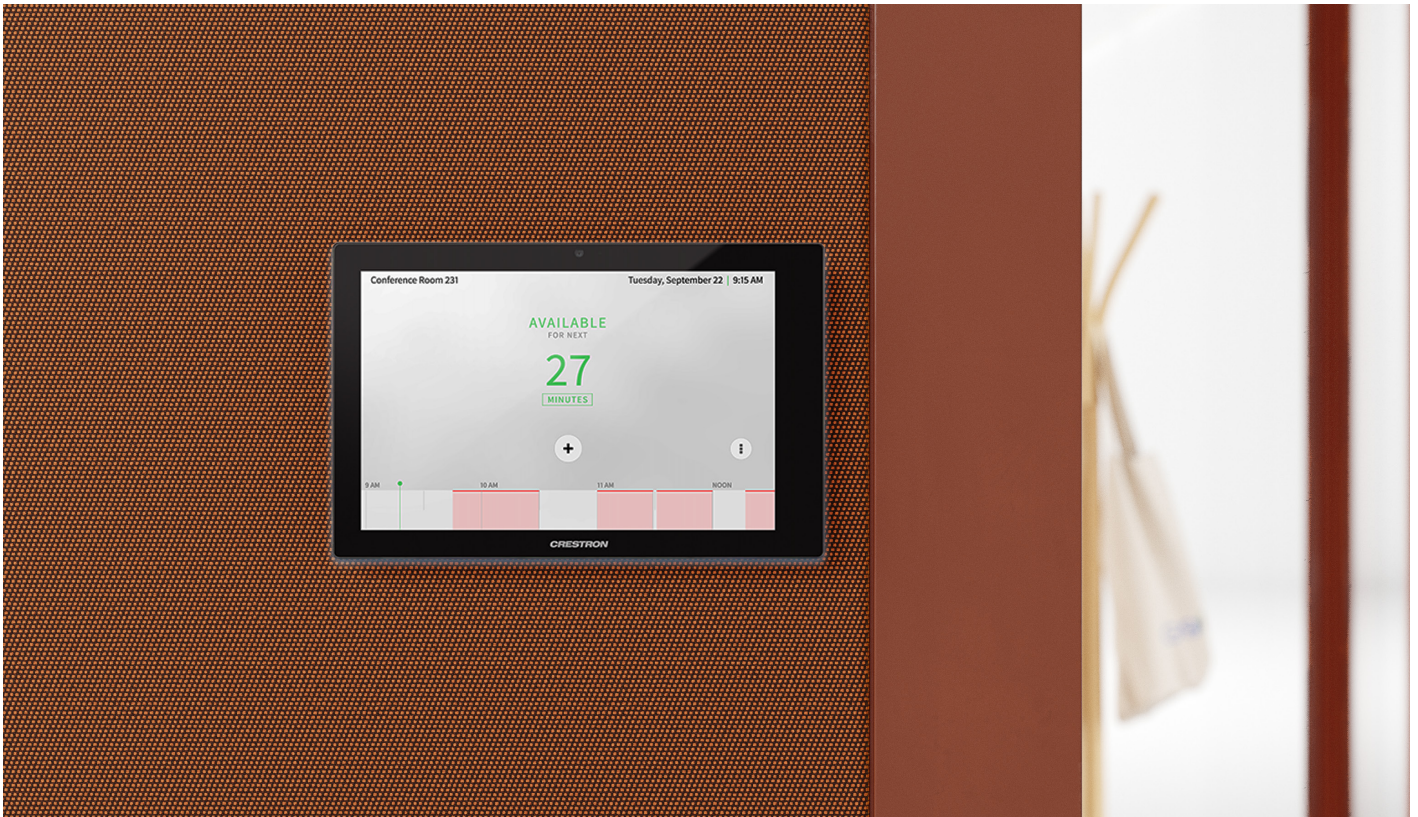

Safety

Key functions

- Smoke detection (*)
- Sprinklers (*)

(*) For technical information see Product Specifications section

(*) Kettal only provides roof adaptation for customer's sprinkler installation



Smoke detector

Sprinklers



Client security hardware integration

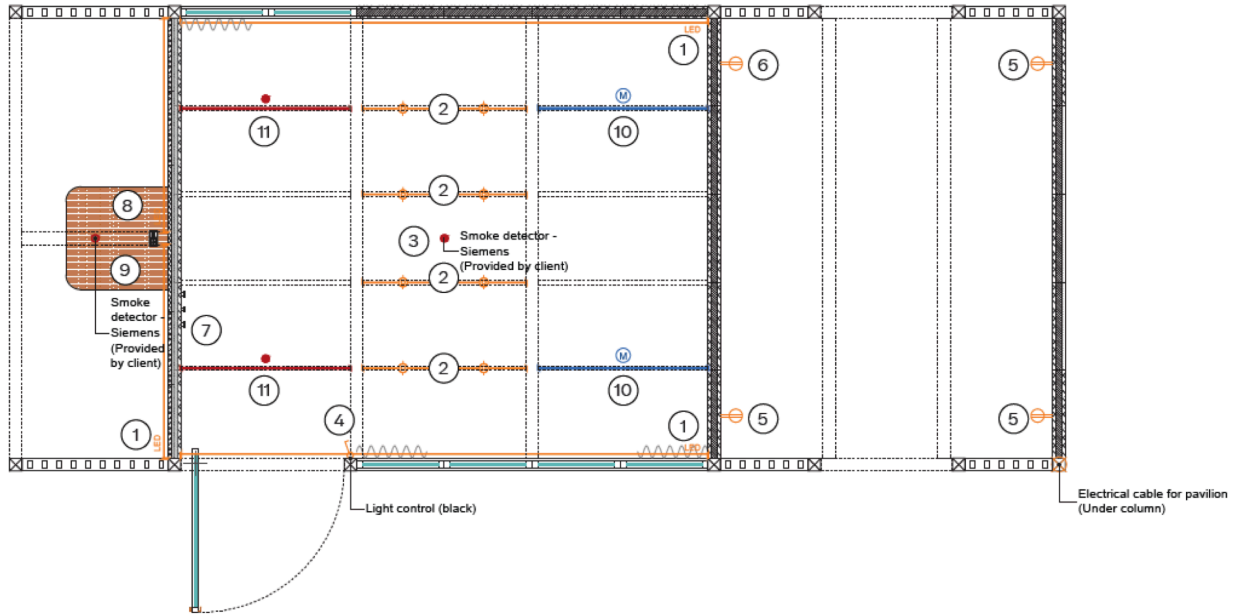

Wall mounted outlets

Key functions

- Data Port
- HDMI
- Power Outlet
- USB
- Configurable
- Shatter-proof
- Flat design line

The outlets are mounted 325cm from floor to center and centered to the panel.

There are different combinations:

- Double plug
- Plug + Net
- Plug + USB A + USB C

15/6

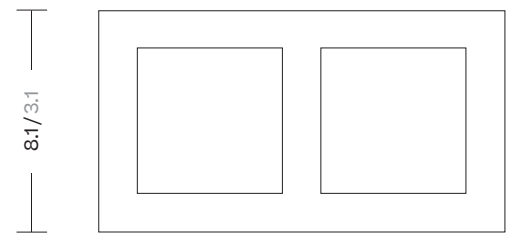

cm/Inches



Table mounted outlets

Hardware

- Simple design
- Power Connections
- USB
- Plug and outlet types (UK, FRA, US, SUI, AUS,...)

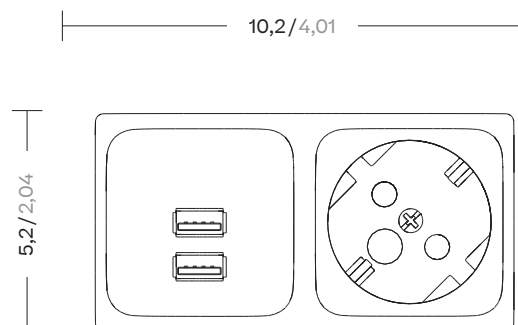

Pavilion O Management System

kettal

Introduction.

Control management

The Pavilion system allows 4 project layers depending on what the client prefers:

| | Stand Alone | Hub Basic | Hub Server Pro | Hub Bacnet |
|-----------------------------------------------------------|-------------|-------------------------------|----------------|------------|
| Control from presence sensor and push buttons | ✓ | ✓ | ✓ | ✓ |
| Control / Dimming from app and mobile device | ✗ | ✓ | ✓ | ✓ |
| Status / Occupation | ✗ | ✓ (información % instantaneo) | ✓ | ✓ |
| Location map Statis / Occupation | ✗ | ✗ | ✓ | ✓ |
| Usage hours | ✗ | ✓ (información % instantaneo) | ✓ | ✓ |
| Air renewal control | ✗ | ✓ | ✓ | ✓ |
| Room booking with schedule | ✗** | ✗** | ✗** | ✓ |
| Notification 10 minutes before the end of the reservation | ✗ | ✗ | ✗ | ✓ |
| Equipment failure warning | ✗ | ✓ | ✓ | ✓ |
| Sensor CO ₂ Bacnet | ✗ | ✗ | ✗ | ✓ |
| Warranty | 2 years | 5 years | 5 years | 5 years |
| Remote support | ✗ | ✓ | ✓ | ✓ |
| Scenes and schedules programming | ✗ | ✓ | ✓ | ✓ |

Extra information:

*In case of not selecting any Hub option, all the material only has a 2-year warranty.

*In case of not selecting any Hub option, we cannot offer remote support.

**Can't be done through the ROS System but can be managed from most of the third part accesory booking screen.

Control management. Pavilion System Layers

Stand Alone

Push buttons/
Dimmer

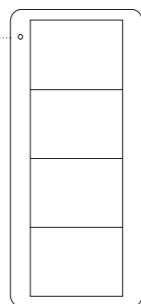

- Push buttons
- Presence sensor
- It doesn't need a Hub
- RFA connection with the Hub
- Lighting control

Hub Basic

Smart device

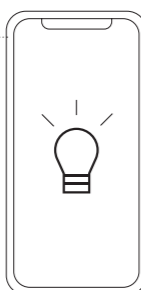

- Works through a Hub & a Management Software
- Smart devices
- Scene control, energy saving, room booking, lighting control

...

Hub Server Pro

Smart device

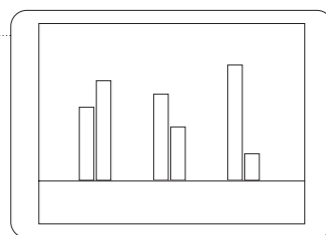

- Server & Hub installed on customer's building
- Includes all functions of Hub Basic
- Allows the management of long-term data

Hub Bacnet



Allows the connection of each Phone Booth and Pavilion O to the building's BMS (Building Management System) through the Bacnet IP protocol.

Control management

The Pavilion system allows 4 project layers depending on what the client prefers:

A. Stand alone

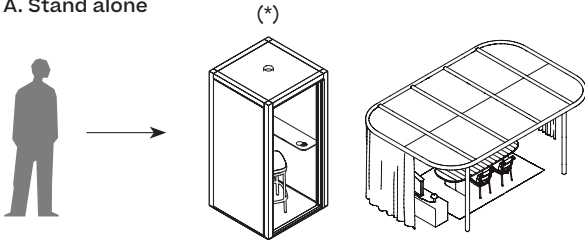

This system allows you to control the lighting from the presence sensor and the push buttons. It is not connected to any control / management system.

(*) Phonebooth only works through presence sensor (always integrated and located under the table). It doesn't have any push buttons.

Presence sensor

The presence sensor is located on the crossbar, and it is previously defined and programmed according to customer needs.

All the rooms come with a sensor by default, but the client can remove it if they prefer.

The sensor can be set by time and operating mode (it can't be configured in the case of Phone Booth). In the following table are defined the different parameters that can be edited in the Sensor configuration.

| Function | Option | Description |
|----------|------------|---------------------------------------------------------------------------------------|
| Auto-ON | Enabled | Sensor turns lights ON and OFF automatically (default setting) |
| | Low Light | Same as Enabled but lights turn ON only in low ambient light conditions |
| | Disabled | Lights turn ON manually only, sensor turns lights OFF automatically |
| Activity | Low | Intended for spaces where occupants will be seated most of the time (default setting) |
| | Medium | Intended for spaces that experience normal activity |
| | High | Intended for spaces where occupants do high motions such as foot traffic |
| Timeout | 30 minutes | Lights turn OFF automatically after 30 min without presence |
| | 15 minutes | Lights turn OFF automatically after 15 min without presence (default setting) |
| | 5 minutes | Lights turn OFF automatically after 5 min without presence |

Push buttons

There are two types of push buttons.

General (dimmer)

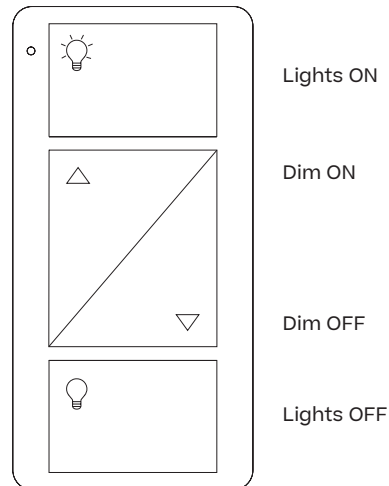

Scene

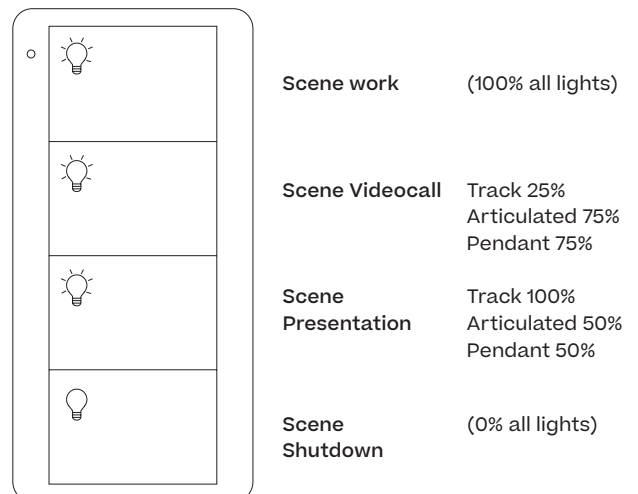

Control management

B. Hub Basic — Control

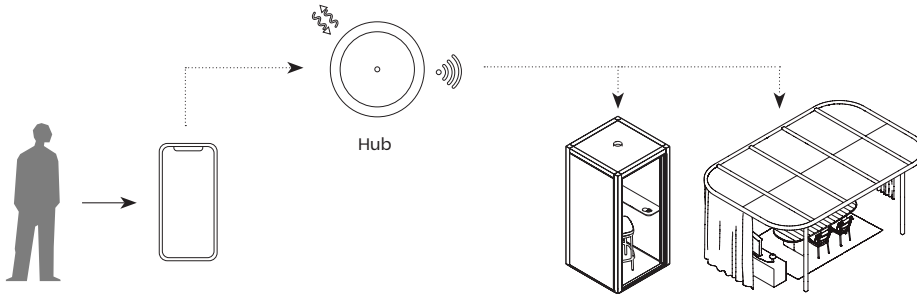

This system includes all of the above and also allows the connection of each Phone Booth and Pavilion O to a Management Software for the client. It can be managed from electronic devices such as mobile, tablet or computer.

This is achieved through a HUB (which is installed in the customer's building), which must be connected to the network (Ethernet) and which interconnects all rooms and Phone Booths. The devices that interact with the HUB must be connected to the same Wi-Fi Network as the HUB, or to the network generated by the HUB itself.

Through this system, it's possible to manage the following* and to get energy saving and room occupancy data at the current time.

Wireless controls and sensors that communicate with the Hub

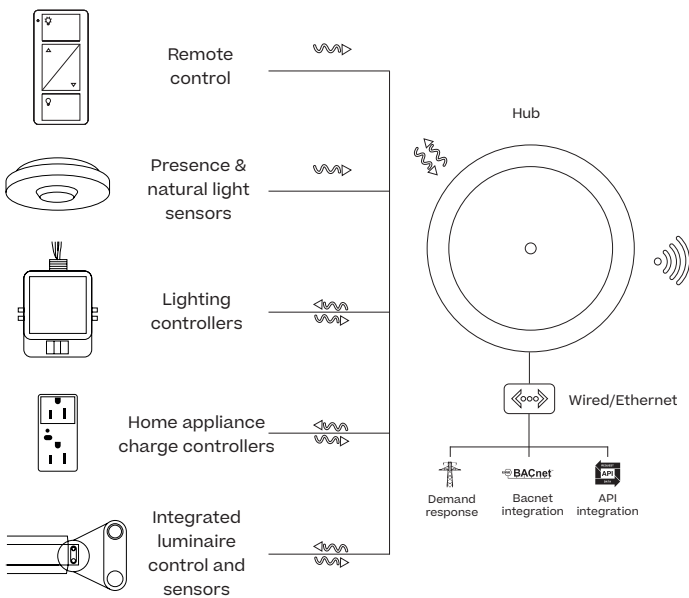

Software interface

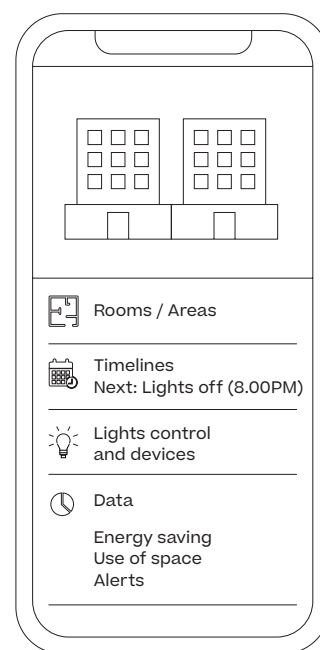

Communication protocols







- Communicate by RF with control components
- Communicate over WiFi with smart devices
- Communicate via Ethernet cable to the hub

1 Hub — 1 interface
Many hubs — Many interfaces

Control management



















B. Hub Basic — Control (Continues)

Through this system, it's possible to manage the following*.

| | | |
|------------------------------------------------------------------------------------|--------------------------------------------|------------------------------------------------------------------------------------------------------------------------------------------------|
|  | Energy saving and space utilization | Quickly review and display energy usage information to make decisions and demonstrate savings. |
|  | Response to electricity demand | Easily set turndown levels that respond automatically during times of peak electricity use. |
|  | Timelines | Use a 365-day calendar to automatically adjust lights based on the time of day, including single-day events and holidays. |
|  | Scene control | Create and configure scenes to control individual devices, areas, or groups of areas on demand. |
|  | Lighting control | Directly adjust light levels remotely from any smart device. Easily respond to occupant requests without the need to be in the physical space. |
|  | Alerts | View proactive alerts that show issues like low batteries or inactive devices to help improve building maintenance efficiency. |

Lighting control strategies to maximize efficiency

Potential saving

| | | | |
|-------------------------------------------------------------------------------------|-------------------------------------------------------------------------------------|-----------------------------------------------------------------------------------------------------------------------------------------------------------------------------------------|-----------------------------|
|  |  | An occupancy/vacancy sensor turns lights on when occupants are in a space and off when they vacate. | 20 - 60% Lighting |
| Busy: ON | Empty: OFF | | |
|  |  | Daylight harvesting dims electric lights when there is daylight that can brighten the environment. | 25 - 60% Lighting |
| Completely ON | Attenuated | | |
|  |  | Scheduling allows for pre-programmed changes in lighting levels, based on time. | 10 - 20% Lighting |
| 7:00 am attenuated | 7:00 pm OFF | | |
|  |  | Demand response automatically reduces lighting loads during times of peak electricity use. | 30 - 50% Peak period |
| Completely ON | Attenuated | | |
|  |  | Plug-in load control automatically turns off loads after occupants leave the space. | 15 - 50% Controlled load |
| ON Device | OFF Device | | |
|  |  | High-level dimming sets the maximum light level based on customer requirements in each space. | 10 - 30% Lighting |
| Max: 100% | Max: 80% | | |
|  |  | Personal dimming control allows occupants to adjust the light level. | 10 - 20% Lighting |
| Completely ON | Attenuated | | |
|  |  | HVAC integration controls heating, ventilation and air conditioning systems via contacts or the BACnet protocol. | 5 - 15% HVAC |
| Heating | Cooling | | |
|  |  | System's Optimization Service identifies important adjustments to lighting control to save additional energy and create a more productive work environment, on an ongoing basis. | Variable |
| Before | After | | |

Control management

C. Hub Server Pro — Control + Management

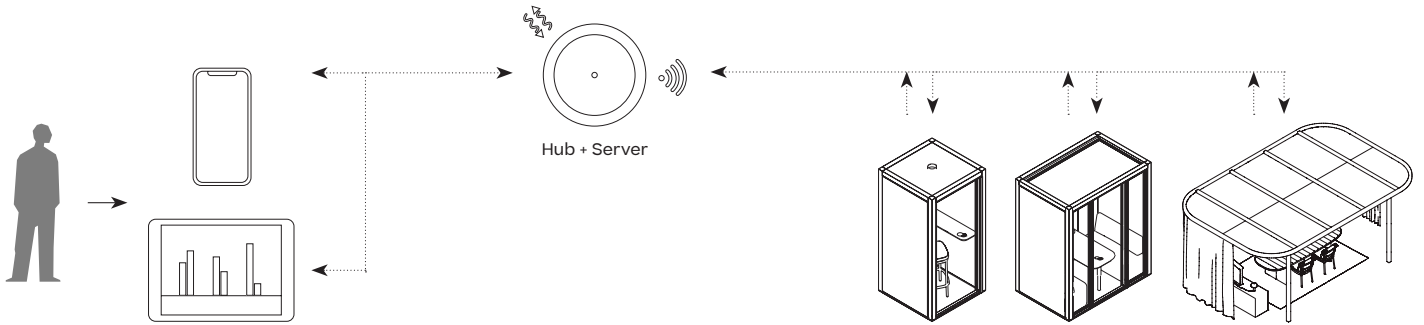

This system includes all of the above and also allows the connection of each Phone Booth and Pavilion O to a Management Software for the client.

This project layer allows for much greater control and visualization of data.

This is achieved through a HUB (which is installed in the customer's building), which must be connected to the network and which interconnects all rooms and Phone Booths. In addition, a server must be installed to be able to manage all the data and activate the system's functionalities:

Intuitive control

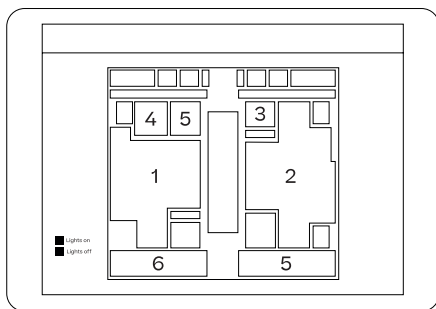

See status, control lights and optimize your building quickly and efficiently with a graphical plan. For example, a screen outside the room with a graph describing the status of all rooms.

Space optimization

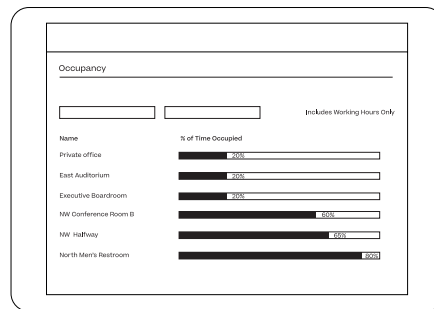

Improve building layout based on actual occupancy and usage information. With space utilization reports, you can quickly identify overused and underused spaces to improve building efficiency without expanding your footprint.

Save energy with a certain goal

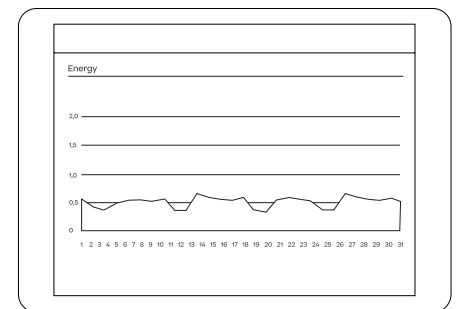

Energy reports allow you to view and control your energy savings. With insights into energy consumption trends over time and easily customizable reports, Vive Vue software helps you demonstrate the energy-saving benefits of wireless lighting control.

Control management

D. Hub Bacnet — Bacnet Integration

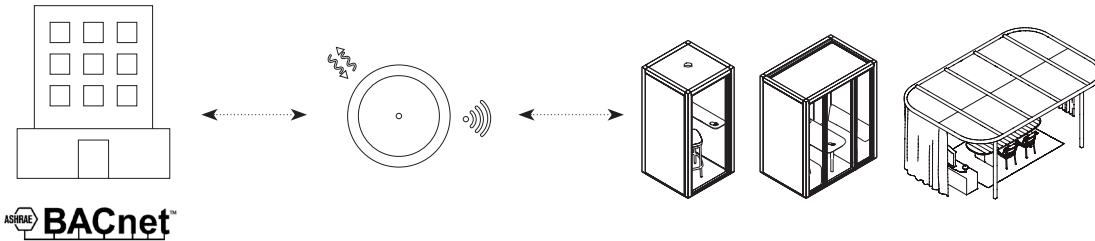

Allows the connection of each Phone Booth and Pavilion O to the building's BMS (Building Management System) system through the Bacnet IP protocol.

This is achieved through a Bacnet licensed Hub (which is installed in the customer's building), which must be connected to the network and which interconnects all rooms and Phone Booths.

How to determine the number of Hubs per project

The number of Hubs per project should be studied based on the layout of the rooms and the project based on the following product specifications.

It is necessary to connect to the customer's network through the RJ45 connection provided by the Hub.

All wireless devices to be associated with the wireless hub must be within 22 m (71 ft) of the wireless hub and must be on the same floor as the hub.

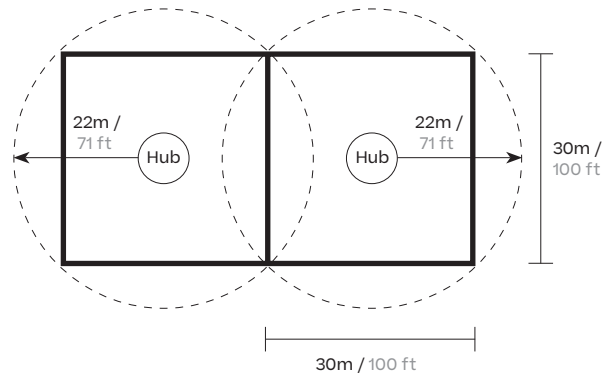

* See more information of the Pavilion Management System in the Annexes.

Pavilion O

Technical data

kettal

General data

The electrical system within the Pavilion O is designed to be discreet, elegant and practical. Embedded in the structure, it is easily accessible and thought within the design.

Electrical input



Connection from underfloor

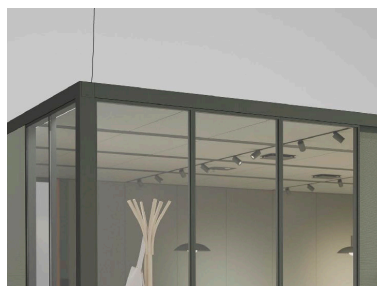

Connection from ceiling

Electrical HUB

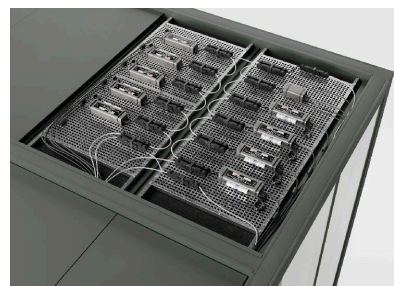

Modular wiring

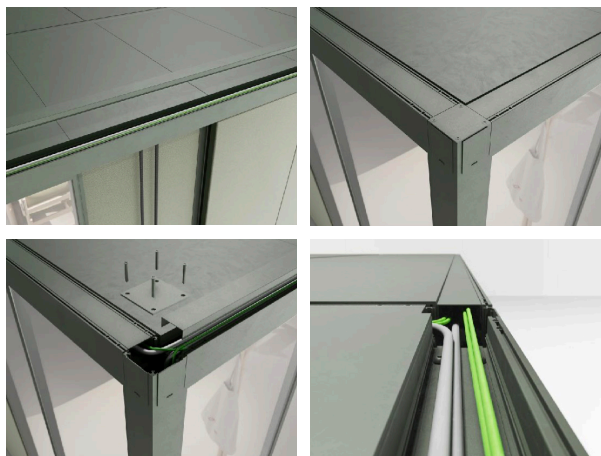

Wiring to panel connection



General data

Electrical line

The electrical system of the pavilion is divided into the following distribution lines:

**C1 Voltage Input: 100-240VAC (single-phase)
Frequency Input: 50-60Hz**

This line will be necessary as long as they are installed in the pavilion any of these accessories:

- Lighting
- Ventilation
- Control
- Network distribution System

The customer must provide a multiconductor cable of at least 3x2.5mm² (L, N, G).

The technical specifications of the cable and the protection of this line must comply with the electrical regulations of the applicable country.

The maximum diameter of the multiconductor cable coating must not exceed 14mm.

**C2 Voltage Input: 100-240VAC (single-phase)
Frequency Input: 50-60Hz**

This line will be necessary as long as any of these accessories are installed in the pavilion:

- Power outlets
- USB charger units
- Soundbar

The customer must provide a multiconductor cable of at least 3x2.5mm² (L, N, G).

The technical specifications of the cable and the protection of this line must comply with the electrical regulations of the applicable country.

The maximum diameter of the multiconductor cable coating must not exceed 14mm.

Network line

This line will be necessary as long as any of these accessories are installed in the pavilion:

- TV Panel
- Room booking
- Network Plug

The entire network system at the level of wiring and connections comply with the CAT6A standard.

The client must supply a network cable based on the specifications of its installation and the regulations that apply.

General data

Power connection

Pavilion O has 3 power and network connection systems:

1. Connection through the base of the column

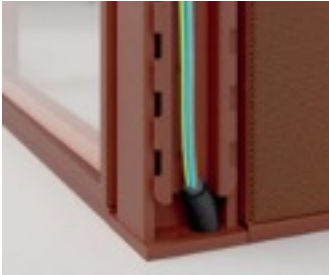

Illustration 1 - Power and data connection through column base

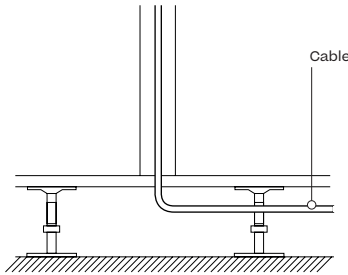

Illustration 2 - Cable route under technical flooring

When:

If the client has a raised floor and prefers the room's power supply connection to be hidden.

How:

At the room base labelled "power supply and data input", Kettal will provide 5 metres of multicore cable (3G 2.5mm²) to connect the room to the power supply line provided by the client.

The end of the above-stated multicore cable will be fitted with a (male) GST18i3 connector. For safe, quick connection, Kettal provides a female connector to attach to the client's cable that is of the same type as the connector in the room.

A 5 meter RJ45 (male) CAT6A network cable is also supplied to connect the pavilion data system.

2. Connection through one side of a column



Illustration 3 - Power and data connection through column side

When:

If the client does not have a raised floor and needs a surface-laid connection to the pavilion, the client must select this type of connection for the room.

How:

The column selected as "power supply and data input" will have a (male) GST18i3 surface connector and a RJ45 CAT6A connector. The client must provide a power line up to that point.

To make the connection, Kettal provides a (female) GST18i3 connector which the client must attach to their power cable to enable simple, quick connection to the pavilion. The customer must also reach that point with an RJ45 cable (male) to connect to the pavilion

2. Connection from ceiling

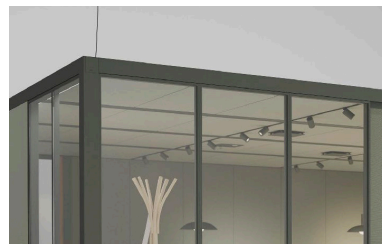

Illustration 4 - Power and data connection from ceiling

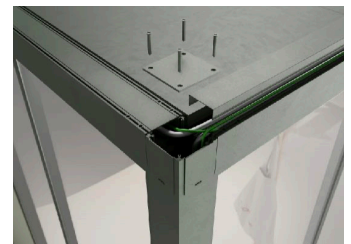

Illustration 5 - Modular wiring

Technical data, Connector

General data

| | |
|-----------------------|--------------------------------|
| Nominal current | 20 A |
| Nominal voltage | 250 V |
| Short-circuit voltage | 4 kV |
| Canopy | Yes |
| Pollution degree | 2 |
| Mechanical coding | Code 1 |
| Lockable | Self-locking (tool release) |
| Colour code | Black |
| Pin marking | L, N, PE |
| Canopy colour | Black |

Connection data

| | |
|--------------------------------------------------------|----------------------|
| Cable diameter, max. | 10.5 mm |
| Cable diameter, min. | 6.5 mm |
| Solid conductor cross-section, mm ² max. | 2.5 mm ² |
| Solid conductor cross-section, mm ² min. | 0.75 mm ² |
| Stranded conductor cross-section, mm ² max. | 2.5 mm ² |
| Stranded conductor cross-section, mm ² min. | 0.75 mm ² |
| Endings per pin | 1 |
| Cable stripping | 38.5 mm |
| Wire stripping | 7 mm |

Material

| | |
|-----------------------------------------------|-----------|
| Casing material | Polyamide |
| Halogen-free | Yes |
| Contact material | Cu-Zn |
| Heat load | 0.089 kWh |
| Insulation components, continuous temperature | 100°C |



Illustration 3 - (female) GST18i3 connector for the client's power line

Control

PIR Sensor

Using the established settings, the presence sensor (PIR) enables automatic control of lighting and ventilation.

Operation:

Entry – When a person enters the room in OFF state, all luminaires switch on 100% (ON state).

Exit – When the person leaves the room, the lighting and ventilation will switch to the OFF state after 15 minutes.

Room in Use – While the room is in use, the user can regulate the lighting from the button panel or the App (Only with HUB).

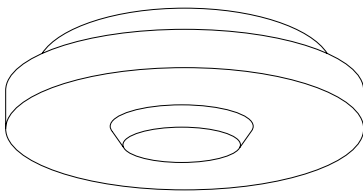

PIR Sensor

Smart devices

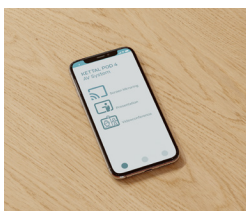

Smartphone



Tablet

* See more information of the Pavilion O Control management in the Management System section.

A system for controlling room lighting using Wireless.

Pavilion O provides 2 ways of controlling lighting:

1. 4-Channel button panel: Each room has at least one 4-channel button panel. This accessory enables interaction with all luminaires.

Location: This item operates through the scenes pre-configured. Among other benefits, it does not need any wiring, so it can be placed anywhere in the room, even inside a piece of furniture (it can be fastened with an adhesive strip). The standard location will be at the column on the door side.

These configurations will come std from the Kettal's factory. in case of having a Hub, the client can modify them

2. APP: Each room and project has a standard setting that enables interaction with all luminaire groups (on, off and adjust)

The settings programmed by Kettal enable the user to have an Administrator account. Only available with Hub system.

Administrator

Overall control of all the project's rooms from a central point. Possibility of modifying, deleting or adding scenes, routines, equipment, etc.

User

Limited control of the rooms' functions. Possibility of turning on, turning off and adjusting separately the different lines in the room.

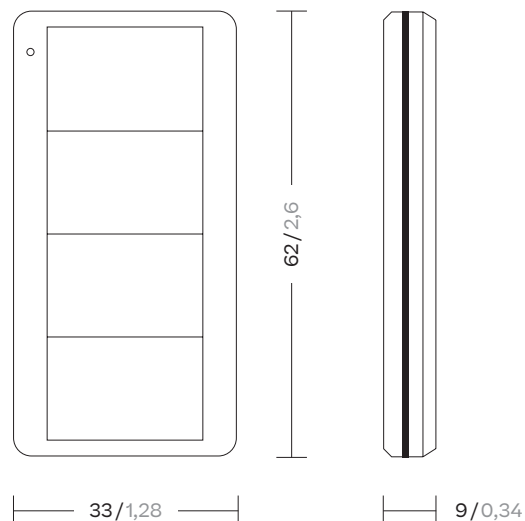

4-channel Casambi button panel (dimensions)

Luminaire groups

Luminaires

The luminaires will be grouped in a standard layout for control by Kettal if no instructions are given otherwise.

As a general rule, groups will be created consisting of: LED Track, Dot Track and Pendant.

There will be one or more luminaire groups of this type, depending on room size. Each group will be identified by a generic photograph to show which type it belongs to.

If the client thinks it necessary, the images, names and luminaire groups can be modified with the Administrator account.

LED Track

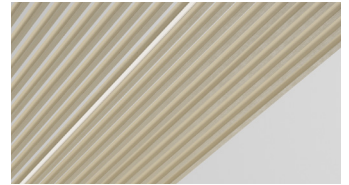

Dot Track Articulated

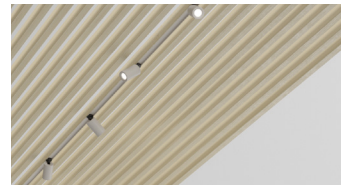

Pendant



* See more information in the Lighting section.

Videoconferences and presentations

All Pavilions O can be equipped with our AV Pack: videoconferencing and presentation equipment for performing any activity to professional standards.

All systems available in the Pavilion O are based on a BYOD (Bring Your Own Device) system. This means that users can use their own devices (laptops, tablets, smartphones ...) to benefit easily, securely and professionally from the room's amenities.

Our AV Pack includes: TV Panel (panel, internal support, plugs and TV stand), Videoconference bar, Wireless System and Room reservation screen. Two years of after-sales service are included with the purchase of this pack.

The equipment can be used with any operating system (Windows, iOS, etc.).

NEC monitor

Smart 4K monitor for professional use for presentations from an external device.



Charging and data accessories on TV Panel:

All TV panels will be equipped with 4 accessories, which will be hidden once the monitor has been installed. These will consist of the following:
 2 Power + Double Network (RJ45 CAT6A)
 + USB/HDMI

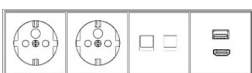

Installation: Installation will be carried out on the Screen or Screen + SoundBar panel

Smart Soundbar & Camera Crestron

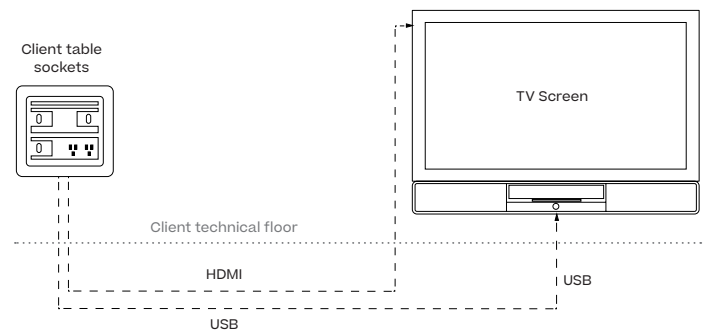

Illustration 5 - Crestron Soundbar & Camera

Connects the user's computer to the room's loudspeakers and camera via USB.

Installation: Installation will be carried out on the Screen + SoundBar panel.

Wiring: The equipment has enough cable length to power the equipment and enough USB cable to reach the central table, where the user's personal device will be located. The necessary cables are provided by Kettal.



This wiring, shown in the image above, must be installed from the TV+SoundBar panel, through the client's raised floor, to where the equipment for controlling the peripheral devices must be located. Our pavilion does not have a raised access floor for routing cables.

If a raised floor is not available for routing the cables and the client wishes to have this equipment in the room, another solution must be found with the client for installing the cables or, alternatively, the Wireless system can be purchased.

AV Panel and AV Integration

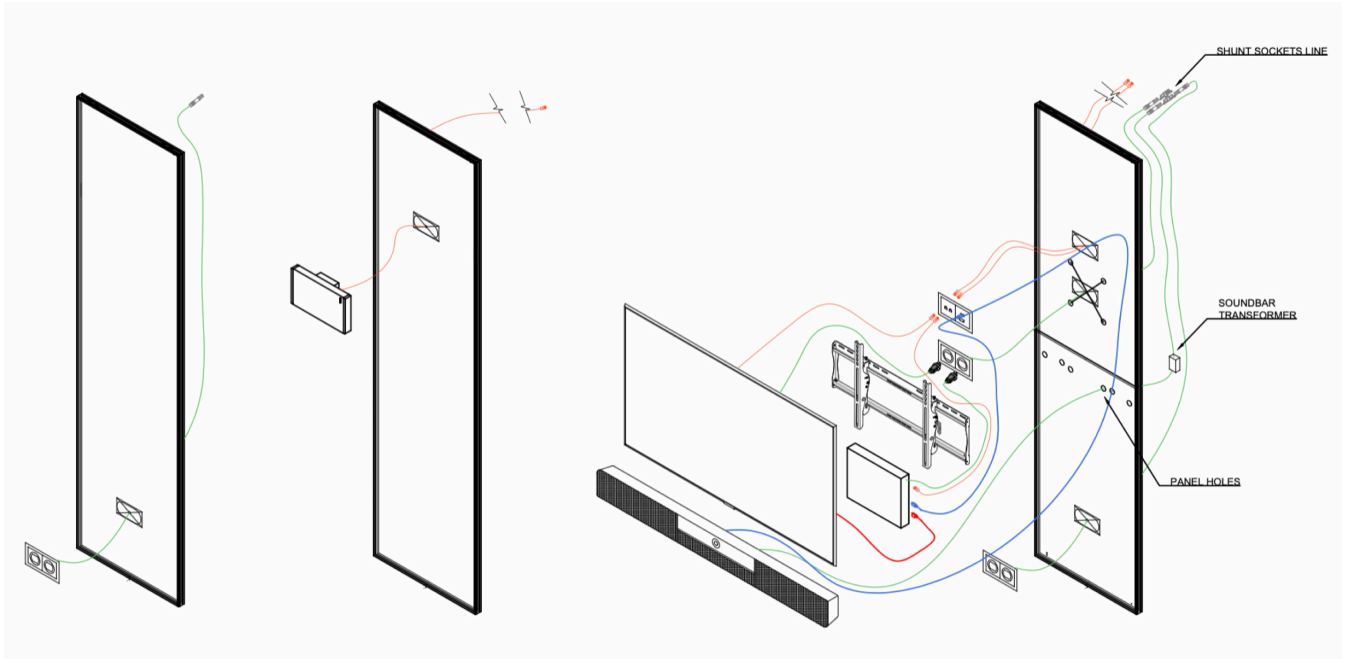

Room reservation screen

IT Network

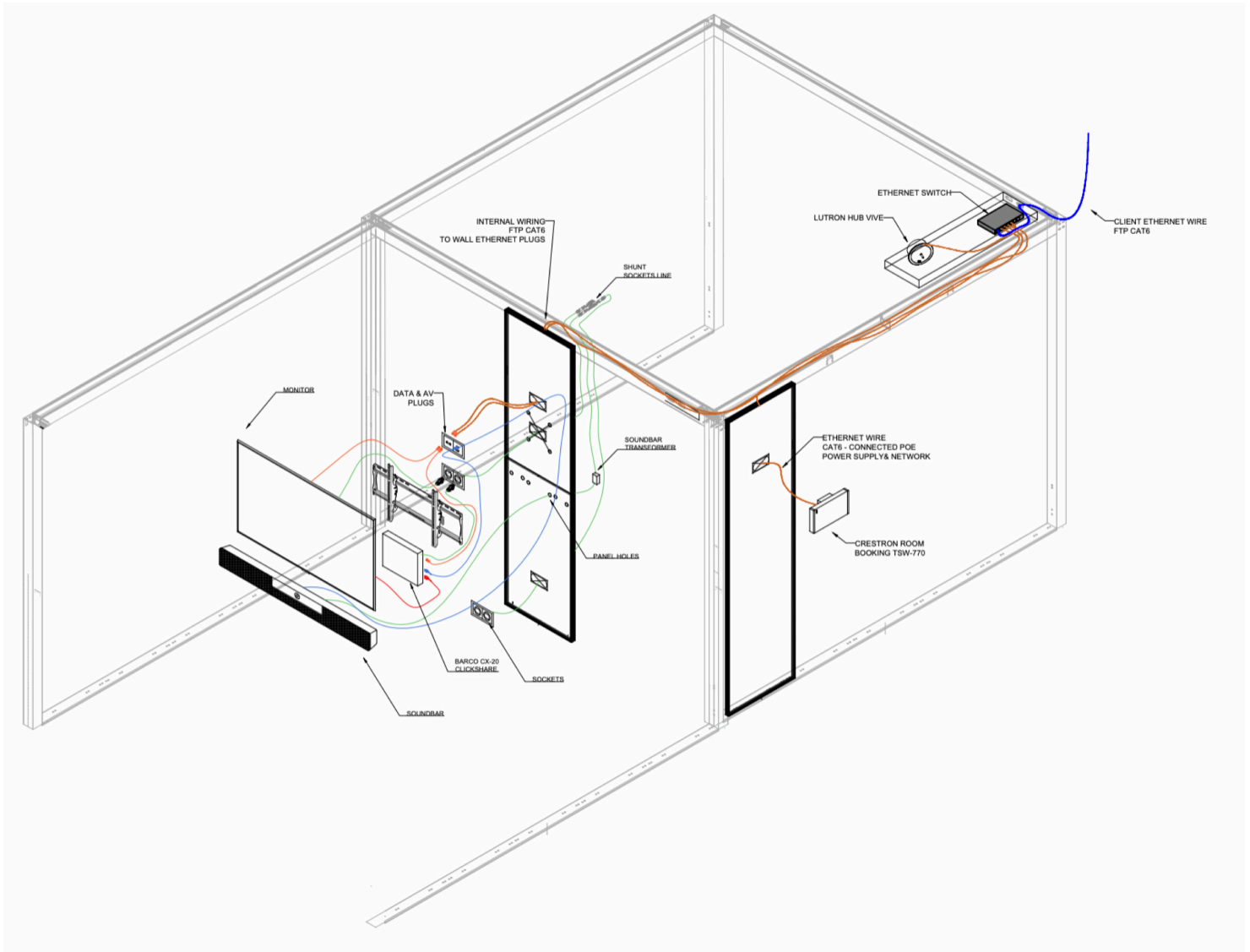

Videoconferences and presentations

Wireless system CX-20

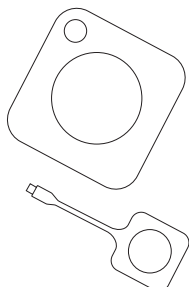

Clickshare CX-20 device

If the client prefers to make wireless connections with the room monitor and the soundbar and camera, they must buy this equipment.

Professional, quickly set-up presentation and videoconferencing system.

With this system, you can connect to the room's peripheral equipment (monitor, soundbar and camera, etc.) remotely, quickly and securely from your personal device (PC, MAC, smartphone or tablet), using any videoconferencing system.

In case the customer has only TV in their living room (without SoundBar), they can select the Barco C-5 equipment. This is best suited for presentation applications.

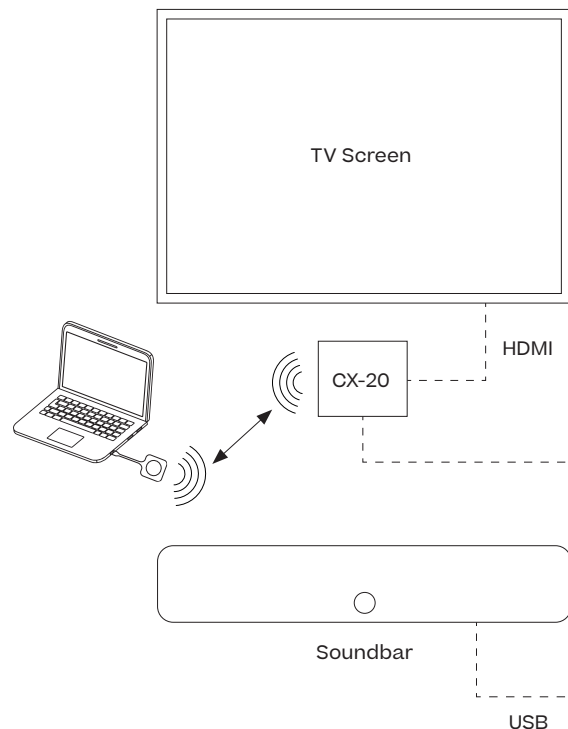

Charging and data accessories

The panels can be equipped with:

2 x Power

- Voltage: 230 VAC 50 Hz (110VAC 60 Hz USA version)
- Settings adapted to country

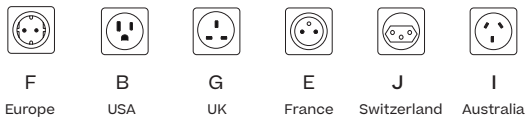

- Maximum power consumption per pavilion must not exceed 16 A
- Each socket can take up to 10 A

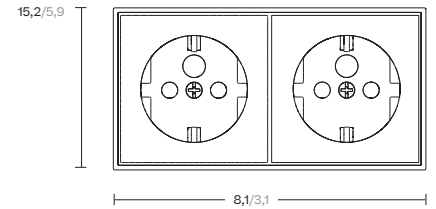

Power + Network

Socket

- Voltage: 230 VAC 50 Hz (110VAC 60 Hz USA version)
- Settings adapted to country

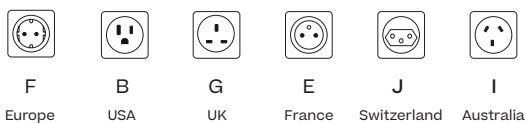

- Maximum power consumption per pavilion must not exceed 16 A
- Each socket can take up to 10 A

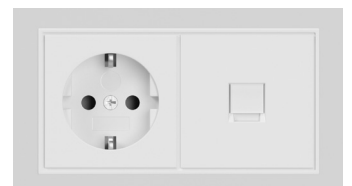
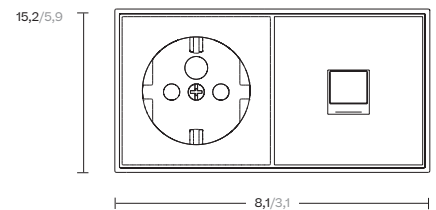

Network socket

- Network connection RJ45 CAT6A
- 8-pin network connection

Charging and data accessories

Power + USB Charge (Type A and C)

- Voltage: 230 VAC 50 Hz (110VAC 60 Hz USA version)
- Settings adapted to country

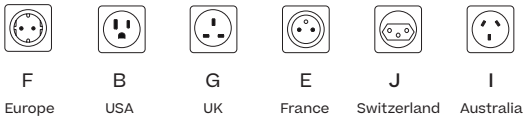

- Maximum power consumption per pavilion must not exceed 16 A
- Each socket can take up to 10 A USB charge
- Number of sockets 2
- 1 type A and 1 type C
- Maximum charging current 3000 mA
- Input voltage: 100-240 VAC 50/60 Hz

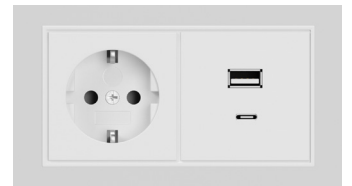
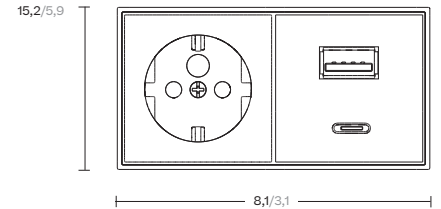

Smoke detector

- Changeable insect protection
- Lithium battery with passivation protection
- Battery life: 12 years
- Processor technology with two sensors (smoke + heat)
- Maximum real alarm precision
- Suitable for kitchen use
- 88 dB alarm signal at distance of 3 m
- Measurements (Ø x H): 10 x 3.8 cm
- Detection range: up to 60 m² (depending on installation conditions)
- Optimal storage temperature: +10 ... + 35°C, <70% relative humidity
- User-friendly, large check/stop key (78 cm²)
- Magnetic fastening with mounting by glue or drill hole
- Compliant with strictest requirements of the vfdb 14-01 directive
- CE in accordance with EN 14604-2005/AC-2008
- TÜV Nord Cert (Kriwan no. 1772-CPR-150500)
- Colour: Alpine white

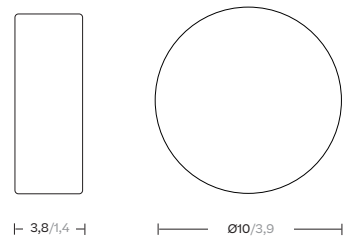

Lighting simulation

Pavilion 4970X5570

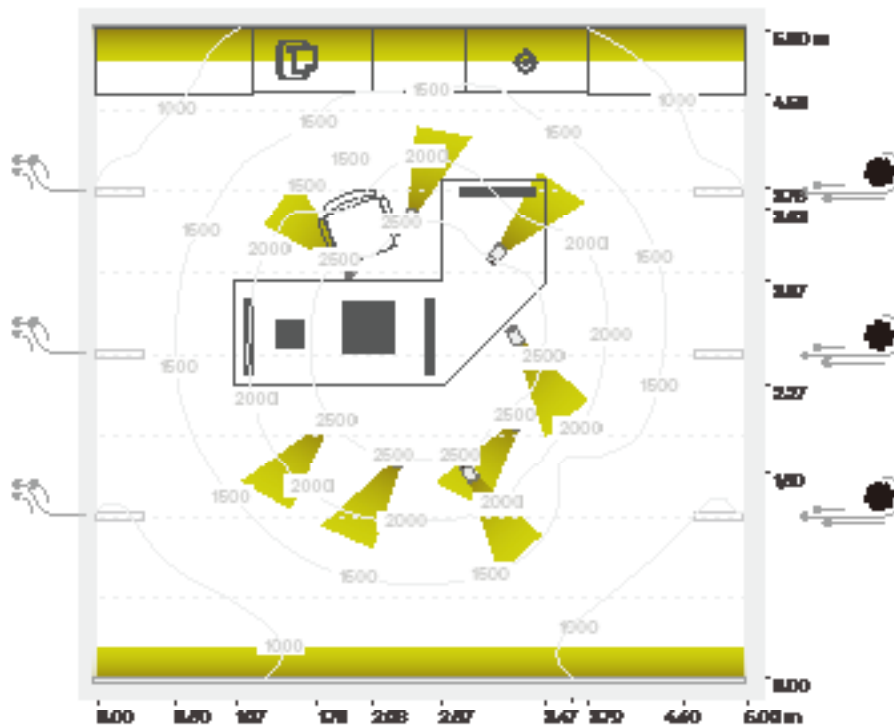

UL 1598 compliance certificate all internal electrical components.

Regulations:

- UNE-EN 60598
- UNE-EN 55015
- UNE-EN 60529

Maintenance

Clean with a smooth cloth. Do not use ammonia products, solvents or abrasives.
 Pursuant to the legislation in force, this product is guaranteed for two years starting from the date of purchase.



| | |
|-----------------------------------------|------------------------------------------------------------------|
| Total (W) | 355 W |
| Input voltage | 100 - 240V |
| Frequency | 50-60 Hz |
| Nominal voltage | 24Vdc |
| Color temperature | 3500K |
| Luminous efficacy | 120lm/w |
| Luminous flux | 43000lm |
| Lighting level | 500 Lx (on a center table) 300 Lx (general space) |
| Average lifetime | 50.000h L80B20 |
| IRC | 90 |
| Light source | Built-in Light source |
| Materials | Aluminium body & PMMA diffuser |
| Dimming control | Kettal provides a ROS integrated homologated |
| Light Electrical consumption (examples) | 417x417cm Room / 4-6P: 287,38W 557x557cm Room / 6-8P: 338,98W |

HVAC

Ventilation

The Pavilion O has a flow rate of 150m³/h per ventilation unit.

It is aimed to have more than 15 air renewals per hour in each of the rooms.

This is calculated for each room size, and the number of machines required is counted: 1, 2, 3, or 4 machines.

Additionally, G3 grade filters are used to filter out dust and ensure proper functioning of the ventilation machines.

Ventilation ceiling (top) location and connection

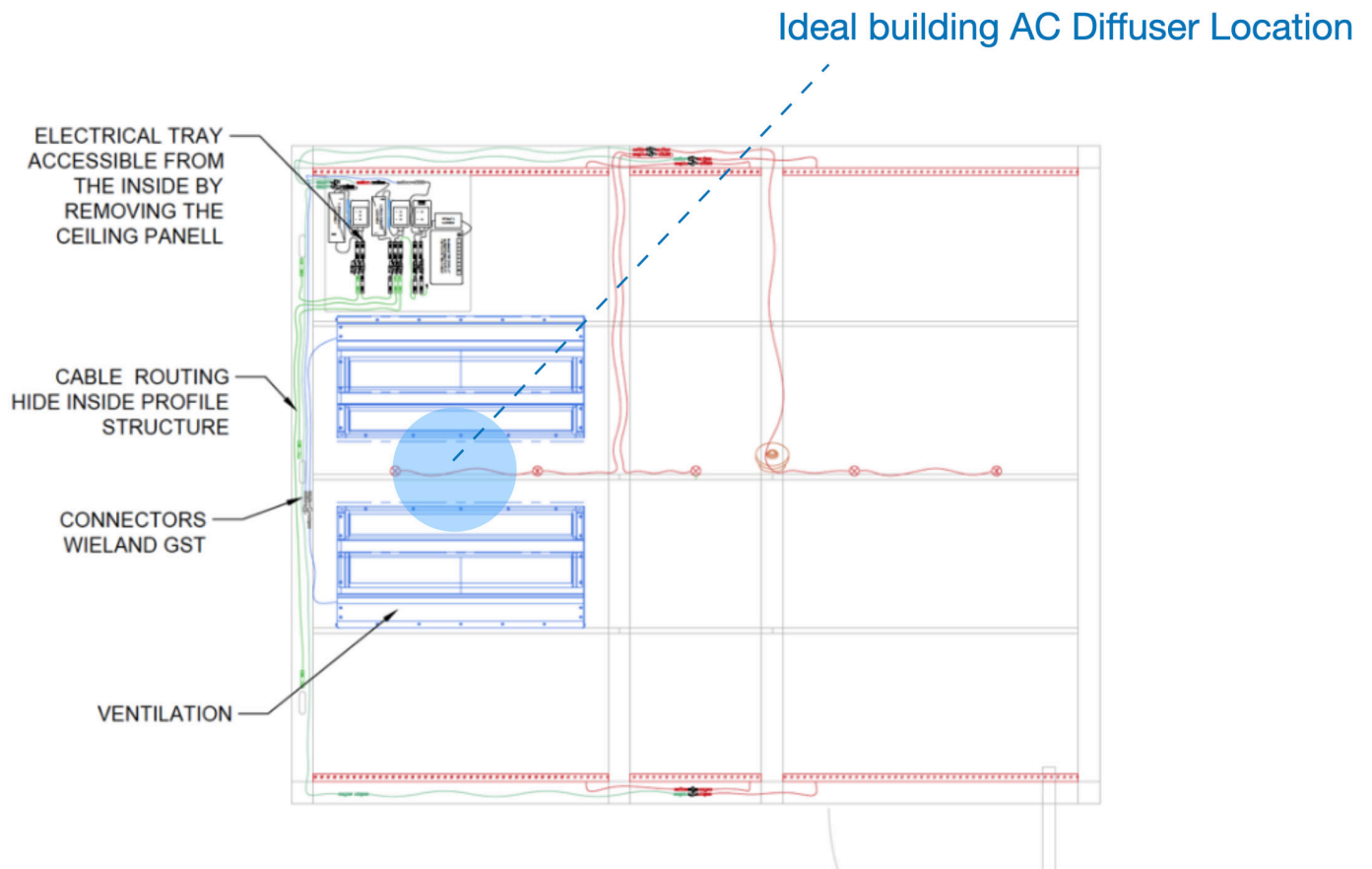

HVAC

Ventilation set-up examples and Air flow efficiency

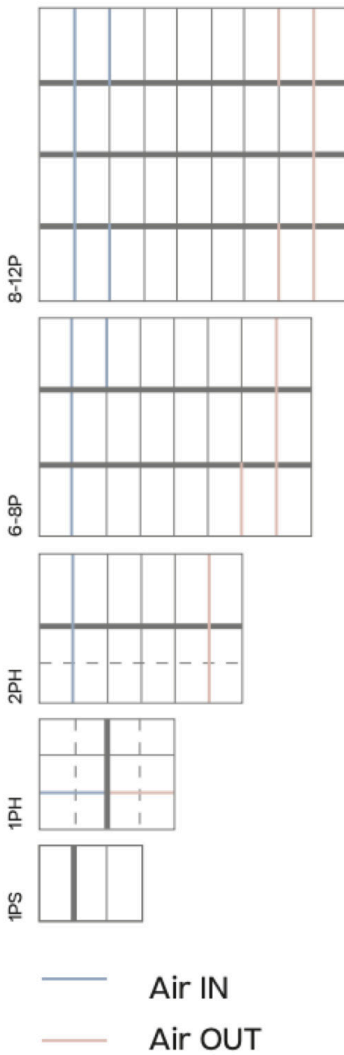

| | | |
|---------------------|--|-----------------------|
| 8-12P | | |
| Height | | 2,31m |
| Weight | | 5,3m |
| Depth | | 4,7m |
| Ventilation modules | | 6 units |
| Flow | | 150 m ³ /h |
| Renewals per hour | | 15,6 |
| Liters per second | | 250 L/s |
| 6-8P | | |
| Height | | 2,31m |
| Weight | | 4,7m |
| Depth | | 3,5m |
| Ventilation modules | | 4 units |
| Flow | | 150 m ³ /h |
| Renewals per hour | | 15,8 |
| Liters per second | | 166,6 L/s |
| 2PH | | |
| Height | | 2,31m |
| Weight | | 3,5m |
| Depth | | 2,3m |
| Ventilation modules | | 2 units |
| Flow | | 150 m ³ /h |
| Renewals per hour | | 16,1 |
| Liters per second | | 83,3 L/s |
| 1PH | | |
| Height | | 2,31m |
| Weight | | 2,3m |
| Depth | | 1,7m |
| Ventilation modules | | 1 units |
| Flow | | 150 m ³ /h |
| Renewals per hour | | 16,6 |
| Liters per second | | 41,6 L/s |
| 1PS | | |
| Height | | 2,31m |
| Weight | | 1,7m |
| Depth | | 1,1m |
| Ventilation modules | | 1 units |
| Flow | | 100 m ³ /h |
| Renewals per hour | | 23,1 |
| Liters per second | | 27,7 L/s |

Pavilion O
Aesthetics & materiality

kettal

Materials

Structural Aluminium

Extruded and hollow profiles of this alloy will be used to build up the structures of each booth.

This is a light and ductile alloy, with great strength and magnificent finishing characteristics. It is ideal for works that require high quality and perfect finishes.

It has excellent corrosion resistance, similar to that of stainless steel. Follows the UN-EN-AW 10204 3-1 regulation.

KETTAL uses 80% recycled aluminum in the extrusion of its profiles in order to reduce greenhouse gases, thus contributing to a more sustainable production of our customers' products.



Recyclable



80% recycled



Local supplier

Chemical composition (UN-EN 10204 3-1 Regulation)

| % | Min. Máx. |
|----|--------------|
| Si | 0.30 0.60 |
| Fe | 0.10 0.30 |
| Cu | - 0.10 |
| Mn | - 0.10 |
| Mg | 0.35 0.60 |
| Cr | - 0.05 |
| Zn | - 0.15 |
| Ti | - 0.10 |

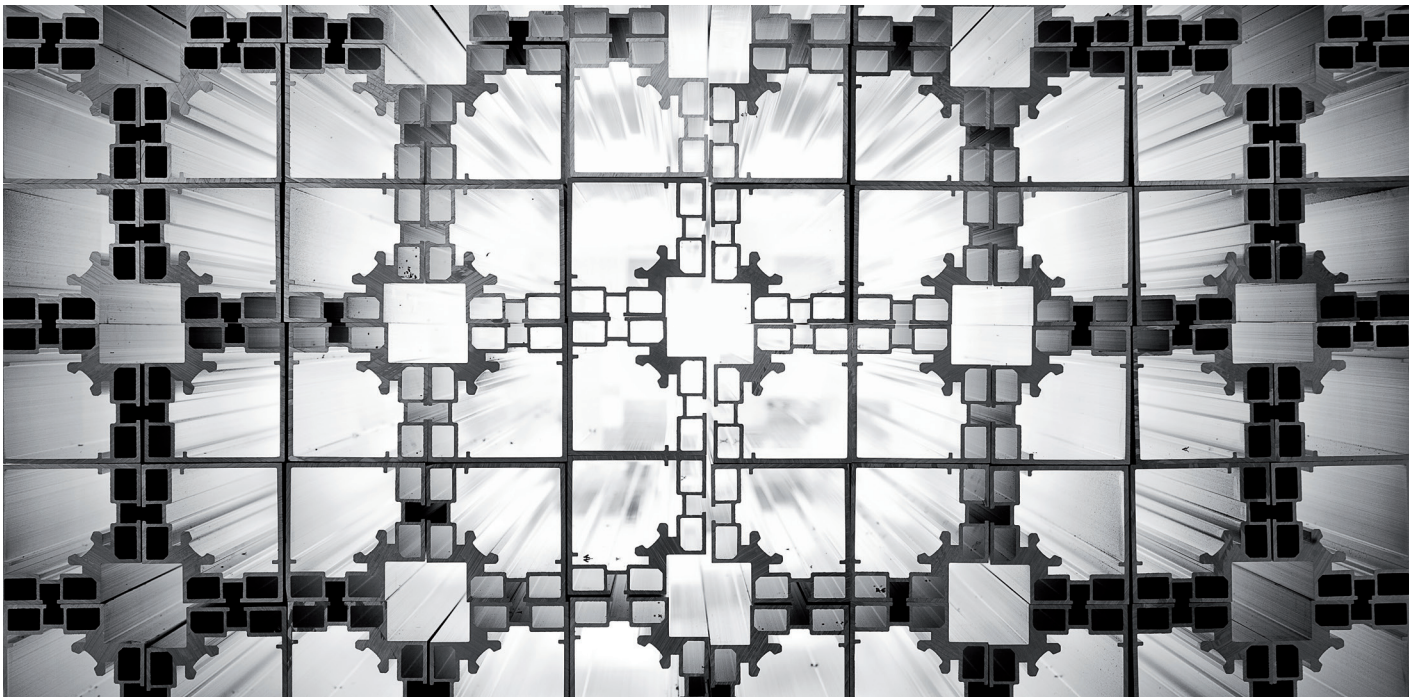

Materials

Technical wood

The technical wood is one of the main components to create the acoustic lateral panel and ceiling. 10mm fire-fighter. Complies with E1 regulation

The environmental product declaration is in accordance with ISO 14025 and EN 15804.

Comply with standards EN 622- 1, EN 622-5 and EN 14322. They are considered reliable products used as raw material for the construction and furniture industry.

| Characteristics | Test | Units |
|---------------------------------|-----------------------------|--------------|
| Density | EN 323 | kg/m3 |
| Flexural strength | EN 310 | N/mm2 |
| Formaldehyde emission | EN 717-1 | ppm |
| Reaction to fire | EN 13501-1 | Euroclase |
| Absorption acoustic coefficient | UNE EN 13986:2006+A 1 :2015 | α |
| Acoustic insulation | UNE EN 13986:2006+A 1 :2015 | db |
| Biological durability | UNE EN 335 | Clase de uso |



Type 2
From cradle to gate with options



Local supplier



Formaldehyde free



Materials

Soundproof Safety Glass

6 mm / 1 PVB / 6 mm

Soundproof safety glass, consists of two or more glass sheets joined by one or more Polyvinyl Butiral (PVB) films,

Direct acoustic isolation 39 dB.

If a laminated glass is broken, the PVB film retains a large part of the glass fragments, that is, the residual strength and the maintenance of the glazing are kept in the same place until they are replaced.

These glasses filter 99% of the UV rays and contribute to extend the life of curtains, rugs, fabrics, objects, etc., which are exposed daily to natural light.

It offers protection against a need for security and complies with the requirements of current norms and regulations, both for homes, shops or offices.

In case of breakage, the fragments remain attached to the sheet.

Chemical composition

| | |
|--------------------------------|-----------|
| SiO ₂ | 69 - 74 % |
| Na ₂ O | 10 - 16 % |
| CaO | 5 - 14 % |
| MgO | 0 - 6 % |
| Al ₂ O ₃ | 0 - 3 % |
| Others | 0 - 5 % |



Belgian supplier



Soundproof safety glass



Materials

Terrain Coatings

Terrain Coatings are designed for aluminum profile coatings used in architecture and for other substrates where maximum outdoor resistance is needed.

It is a powder coating formulated with polyester resins and free of TGIC, pigments and additives. They offer excellent exterior durability with very good gloss retention and color stability.



Class A2



Polymerization
at 160°



Local supplier



Materials

Terrain Coatings

| Characteristics | Min. | Max. | Method |
|---------------------------------|-------------------------------|-------------------------------|------------|
| Baking time / temperature | 24 to 150 °C / 75,2 to 302 °F | 26 to 150 °C / 78,8 to 302 °F | Total time |
| Gloss at 60° angle | 6 | 9 | ISO 2813 |
| Direct impact 12.5 mm | 30 | | ISO 2813 |
| Indirect impact 12.5 mm | 30 | | ISO 2813 |
| Cross-cut adhesion | 0 | 0 | ISO 2813 |
| Erichsen Cupping test | 5 | 11 | ISO 2813 |
| Bend test (Cylindrical Mandrel) | | 6 | ISO 2813 |
| Avg. Particle size | 50 | 55 | MALVERN |
| Particle size % < 100 MICRONS | 80 | 95 | MALVERN |
| Particle size % < 50 MICRONS | 50 | 65 | MALVERN |
| Particle size % < 10 MICRONS | 4 | 8 | MALVERN |
| Delta E colour | | VISUAL | CIELAB |
| General appearance | Textured | | NIZI-001 |

Certificates



Materials

Kvadrat Relate Fabrics

Relate is a sophisticated twill weave upholstery textile designed by Patricia Urquiola made from Trevira CS, which has a soft hand resembling natural fibres.

The versatile palette for Relate comprises 35 colourways and expresses confident colour combinations by combining warm notes with closely related nuances.

Relate is suitable for contract and private use.

Technical specifications

| | |
|---------------------------|-----------------------------------------------------------------------------------------------------------------------------------------------------------------------------------------------------------------------------------------|
| Composition | 100% Trevira |
| Width | Approx. 140 cm |
| Weight per m ² | Approx. 328/m ² |
| Fire test | AS/NZS 3837 class 2, BS 5852 Crib 5, BS 5852 part 1 with treatment, DIN 4102 B1, EN 1021-1/2, IMO FTP Code 2010 Part 8, NF D 60 013, NF P 92 503 M1, NFPA 701, SN 198 898 5.2, UNI 9177 Classe 1, US 1 Cal. Bull. 117-2013, ÖNORM B1/Q1 |
| Lightfastness | 5-7 (ISO 1-8) |
| Shrinking | App 2% |
| Abrasion Martindale | 80.000 Martindale |
| Wash load | Half |
| Pilling | 4-5 (ISO 1-5) |
| Colour | Slight differences may occur |
| Produced in environment | Greenguard Certification www.greenguard.org |



Materials

Floor carpet

A subtle linear pattern together with a refreshed colour range provides the perfect counterpoint for contemporary and sustainable interior design. Combining soft floor comforts with a hard floor appearance it gives a laid back, modern and natural feel.

Colour Options



Nordkapp
CP1

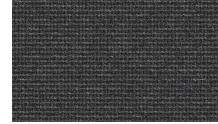

Reykjavik
CP2



Bergen
CP3



Materials

Floor carpet

Technical specifications

| | | | | | | | |
|--------------------------------------------|-----------------------------------------------------|--------|--------|---------|---------|---------|----------------|
| Composition | 100% Solution Dyed Nylon, contains recycled content | | | | | | |
| Pile Yarn Weight (g/m ²) | 400 ± 5% | | | | | | |
| Total Weight (g/m ²) | 3649 ± 5% | | | | | | |
| Total Thickness (mm) | 4.4 ± 0.5% | | | | | | |
| Gauge / Ends 10 cm | 5/64 - 50.4 | | | | | | |
| Tufts per m ² | 176,400 ± 5% | | | | | | |
| Backing Type | Graphlex ® | | | | | | |
| Wear Classification | Heavy Contract (EN 1307) Class 33 / LC1 | | | | | | |
| Radiant Panel | (EN ISO 9239-1) Euroclass Cfl s 1 (EN 13501-1) | | | | | | |
| Dimensional Stability | ≤ 0.2% (EN 986) | | | | | | |
| Impact Sound Insulation (ΔL _w) | 14 dB (EN ISO 10140-3) | | | | | | |
| Rating of Sound Absorption | α _w 0.15 (EN ISO 11654) | | | | | | |
| Sound Absorption | 125 Hz | 250 Hz | 500 Hz | 1000 Hz | 2000 Hz | 4000 Hz | (EN ISO 354) |
| | 0.01 | 0.00 | 0.06 | 0.17 | 0.32 | 0.30 | α _s |



EN 14041



DOP: 1037/116771
textile floor covering
EN 1307

Materials

Terrain Elements

This is a range of premium fabrics for indoor and outdoor furniture. The hydrophobic technology applied works by impeding the liquids that permeate the fabric, forcing them to roll out of the fabric in the form of drops. The fabric protection that brings out the liquids allows for drops of water and oil to be eliminated during normal washing without leaving any traces.

Solution-dyed acrylic; is dyed before thread is created. A liquid acrylic solution is mixed with dye and then formed into a fiber and spun on thread.

Composed of different 3 shades of unique colors.

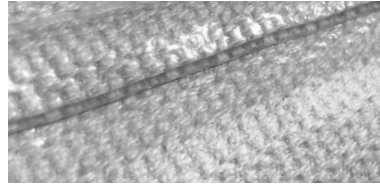

Thermal welding in all stitching applied

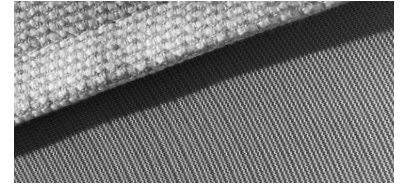

Air circulate system



Water repelent



Laminated



Anti-mould



UV-Resistant



NFPA 260



CAL 117

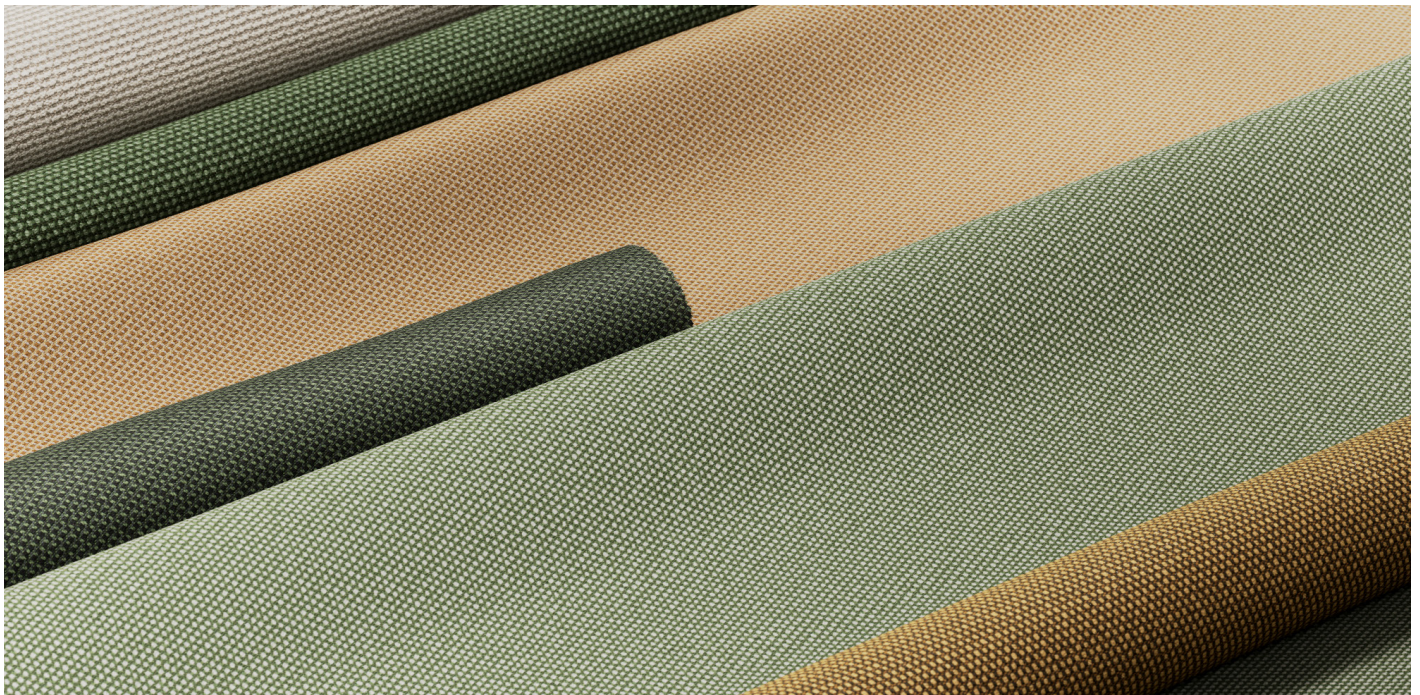

Materials

Technical Specifications

| | | |
|-----------------------------------------------|--------------------|-------------|
| Material | 100% acrylic, dyed | |
| Grammage | 400 g/m2 | ISO 2286-2 |
| Resistant to superficial wetting | 100 ISO 24920 | ISO 24920 |
| Oil resistance | 6 | AATCC 118 |
| Colour fastness to artificial weathering | 7-8 blue scale (8) | ISO 105-B04 |
| Colour fastness to light | 7-8 blue scale (8) | ISO 105-B02 |
| Title warp and weft | Nm 2/34 Nm 6/34 | |
| Tensile strength, warp | 180 daN/5 cm | ISO 13934 |
| Tensile strength, weft | 240 daN/5 cm | ISO 13934 |
| Tear resistance, warp | 21.0 daN | ISO 4674-1 |
| Tear resistance, weft | 29.0 daN | ISO 4674-1 |
| Abrasion resistance (Martindale) | 30,000 cycles | ISO 12947-2 |
| Abrasion resistance (Wyzenbeek) | 15,000 double rubs | ASTM D4157 |
| Cigarette ignition classification | Class 1 | NFPA 260 |
| Material resistance to ignition without flame | Pass | CA TB 117 |



Materials

Colour Shades



Charcoal
01L

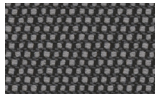

Cumulus
02L

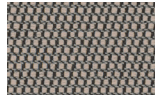

Fog
09L

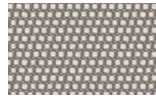

Porous Grey
08L



Snowcap
03L



Moonstone
07L

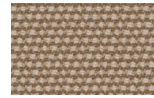

Karakum
06L

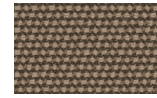

Cambium
12L



Raku
11L

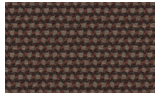

Clove
13L

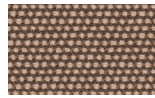

Desert Rose
14L

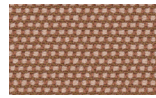

Pink Salt
15L

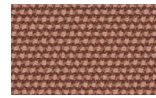

Pacific Dawn
16L

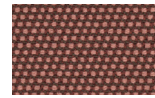

Acer
17L

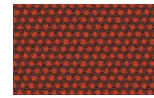

Firetail
18L

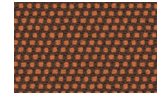

Glowing Ember
19L

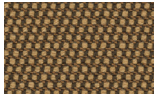

Tiger Eye
05L

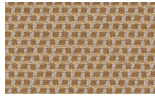

Goldrush
04L

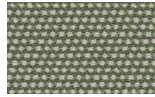

Sea Heart
22L

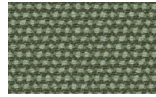

Heath
21L



Peppercorn
20L

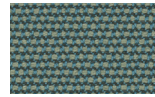

Rock Pool
23L

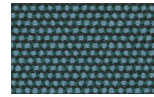

Tropic
24L

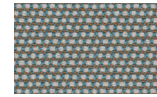

Skylark
25L

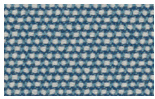

Nautica
26L

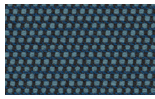

Blue Reef
27L

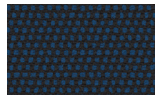

Cosmos
28L

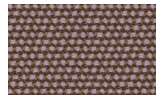

Amethyst
29L

Materials

Maya (Curtains)

Maya is a rhythmic, airy curtain textile designed by Doshi Levien, offering an open structure and a light, matte expression. Despite its delicate look, it is extremely robust.

Constructed with a leno weave, Maya creates a beautiful play of light and shadow, as conditions change throughout the day. The design is inspired by Indian saris, which combine different transparencies to consistently reveal subtle nuances.

Care instructions



Technical specifications

| | |
|----------------|-------------------------------------------------------------------------------------------------------------------------------------------------------------------------------------------------------------------------------------------------------------------------|
| Composition | 100% Trevira |
| Yarn type | Spun |
| Binding | Leno |
| Lightfastness | Note 7 ISO 105-B02 |
| Width | Approx. 300 cm |
| Weight | Approx. 300 g/lin.m |
| Repeat | Approx V. 1 cm H. 0 cm |
| Fire retardant | AS/NZS 1530.3 • BS 5867 part 2 type B • IMO FTP Code 2010 Part 7 • JIS L 1091 A-1 D • NF P 92 507 M1 • NFPA 701 SN 198 898 5.2 • UNI 9177 Classe 1 • DIN 4102 B1 • EN 13 773 class 1 • ASTM E84 Class A Unadhered • CAN ULC S109 • EN 13501-1, B-s1, d0 • AS/NZS 1530.2 |

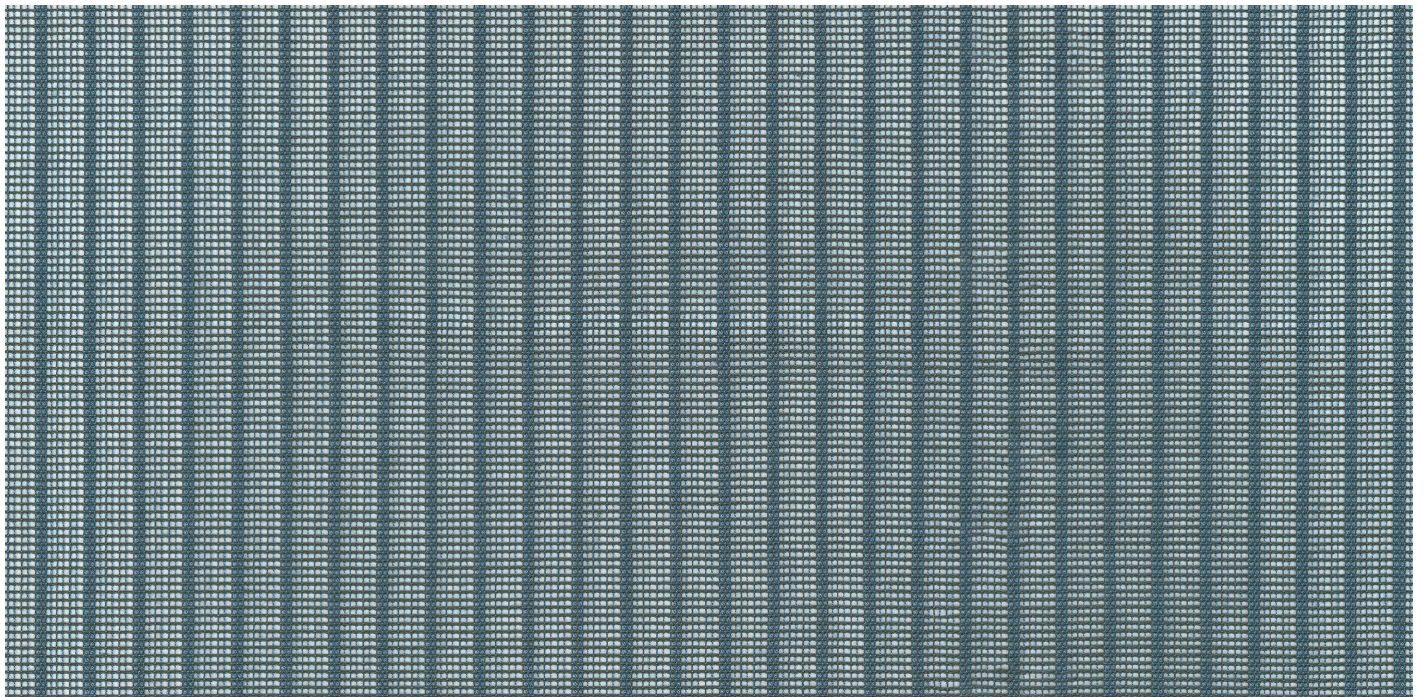

Materials

Technical wood

Technical Wood is made of original tropical hard wood fibers that undergo a high-pressure and high-temperature steaming process. Hence it shares similar characteristics of natural solid wood but has the added advantage of being pest and fungus-resistant, in accordance to the international standard.

Technical specifications

| | |
|----------------------------------------|------------------------------------|
| Density (kg/m ³) | 760-730 EN 323 |
| Flexural strength (N/mm ²) | 14 EN 310 |
| Formaldehyde emission (ppm) | ≤0.05 EN 717-1 |
| Reaction to fire | B-s2,d0 EN 13501-1 |
| Absorption acoustic coefficient (α) | 0.25 UNE EN 13986:2006+A 1:2015 |
| Acoustic insulation (db) | 24 UNE EN 13986:2006+A 1:2015 |
| Biological durability | 1 UNE EN 335 |



Type 2
From cradle to gate with options



Local supplier



Formaldehyde free



Materials

Recycled Cotton Wool

1. Ecological Product. Bio-sustainable. 80% recycled and 100% recyclable.
2. Safe in its installation: It does not cause discomfort or itching as it is based on natural fibers.
3. Elastic product. Does not break when folding. Its modulus of elasticity compared to rock wool is: 7 times better.

It does not promote combustion. Fire classification: M1 Certified 09/32300075 and 76 + according to UNE 23721-90, EN 13501-1.

| Frequency | Rockwool 4cm | Cotton 3cm |
|-----------|--------------|------------|
| 100 | 40,7 | 43,8 |
| 200 | 43,8 | 42 |
| 250 | 46,8 | 33,2 |
| 400 | 47,2 | 46,8 |
| 500 | 47,8 | 53,3 |
| 1000 | 54,4 | 54 |
| 1250 | 55,6 | 56,8 |
| 1600 | 56,6 | 57,5 |
| 2000 | 59,3 | 60,1 |
| 2500 | 61 | 61,2 |
| 3150 | 64,3 | 66 |
| 4000 | 66,1 | 68 |
| GLOBAL | 53 dBA | 54,6 dBA |



Type 2
From cradle to gate with options



Local supplier



Recyclable



Materials

Soundproofing Membrane

High-density, polymer-based, asphalt-free synthetic soundproofing membrane.

Note

No substances including in the LIST OF PROHIBITED SUBSTANCES in CRADLE TO CRADLE CERTIFIED PRODUCTS PROGRAM are used in the manufacturing of the product range Soundproofing Membrane so those substances are not expected to be on the final product.

Restricted Substances (REACH Annex 17)"

The item(s) stated within section "2" of this declaration satisfy the requirements that are defined in Title VIII of Regulation (EC) No. 1907/2006 (REACH regulation), including the restrictions listed in Annex 17 of REACH.

Link: <https://echa.europa.eu/substances-restricted-under-reach>



Local supplier

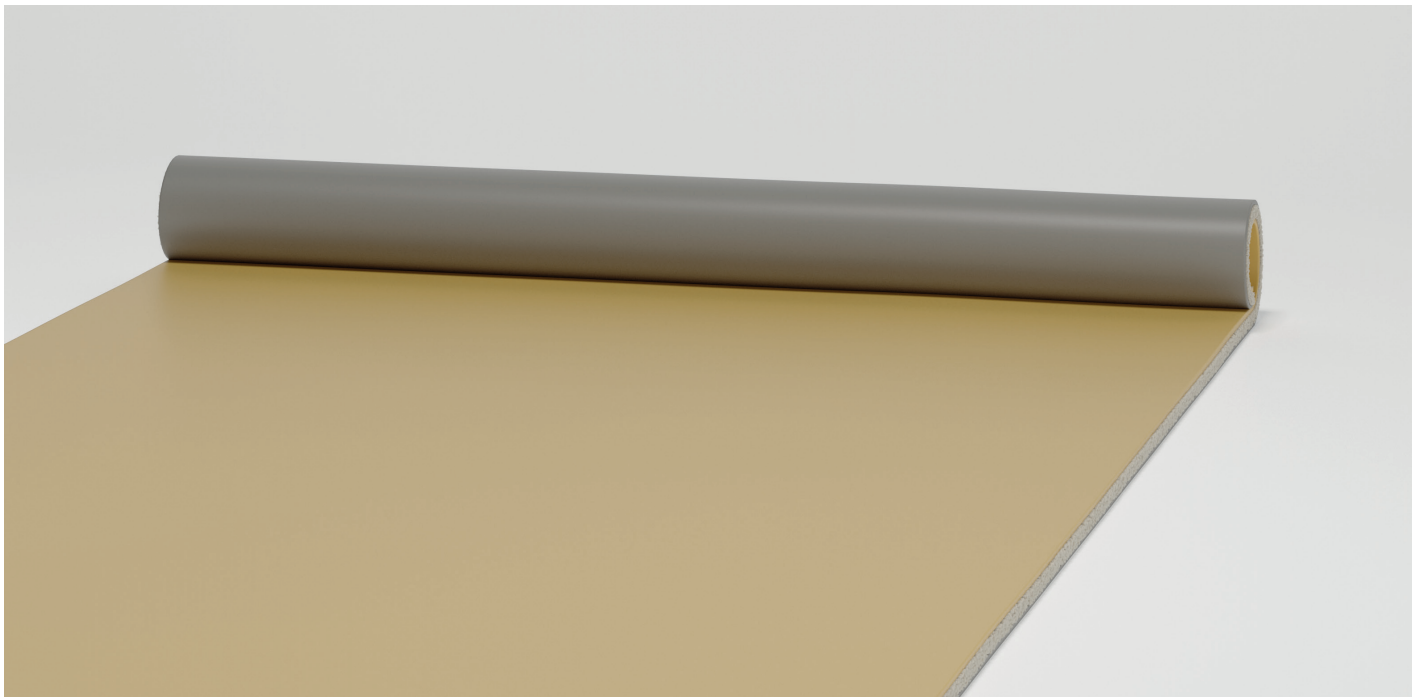

Materials

Soundproofing Membrane

| Characteristics | Testing method | Tecsoundsy | Units |
|----------------------------------|-------------------|------------|-------------------|
| Density | - | 2.010 | kg/m ³ |
| Tensile strength | NT-67 | >30 | N/50mm |
| Elongation | NT-67 | >500 | % |
| Fold | EN 1109 | -20 | °C |
| Fire classification | UNE-EN 13501-1 | Bs2d0 | - |
| Resistance factor to water steam | UNE-EN 1931 met B | μ>1806 | - |
| Water absorption (24h at 23°C) | 1S062 met 1 NT74 | 0,003 | % |
| Shore A hardness | NT74 | 30±10 | |

| Regulation or protocol | Conclusion | Version of regulation of protocol |
|--------------------------|-------------------------------------------------------------------------------------|----------------------------------------------------------------------------------------------------|
| French VOC Regulation |  | Regulation of March and April 2011 (DEVL1101903D and DEVL1104875A) |
| French CMR components | Pass | Regulation of March and April 2011 (DEVL1101903D and DEVL1104875A) |
| AgBB/ABG | Pass | Anforderungen an bauliche Anlagen bezüglich des Gesundheitsschutzes (ABG), Entwurf 31.08.2017 |
| Belgian Regulation | Pass | Royal decree of May 2015 (C-2014/24239) |
| Indoor Air Comfort® | Pass | Indoor Air Comfort 6.0 of February 2017 |
| Indoor Air Comfort GOLD® | Pass | Indoor Air Comfort GOLD 6.0 of February 2017 |
| Blue Angel (RAL UZ 132) | Fail | Low-Emission Thermal Insulation Material and Suspended Ceilings for Use in Buildings, October 2010 |
| BREEAM International | Compliant | GN22 v2.2 (August 2017): BREEAM Recognised Schemes for VOC Emissions from Building Products |
| LEED v4 (outside U.S.) | Compliant | LEED v4 for Building Design and Construction (April 2015) |

Materials

Foam

Innovative thermal and acoustic insulation.

Foams are widely used as sound absorbing materials in noise control engineering.

A foam material is a solid that contains cavities, channels or interstices so that the sound waves are able to enter through them.



100% Recyclable



Local supplier

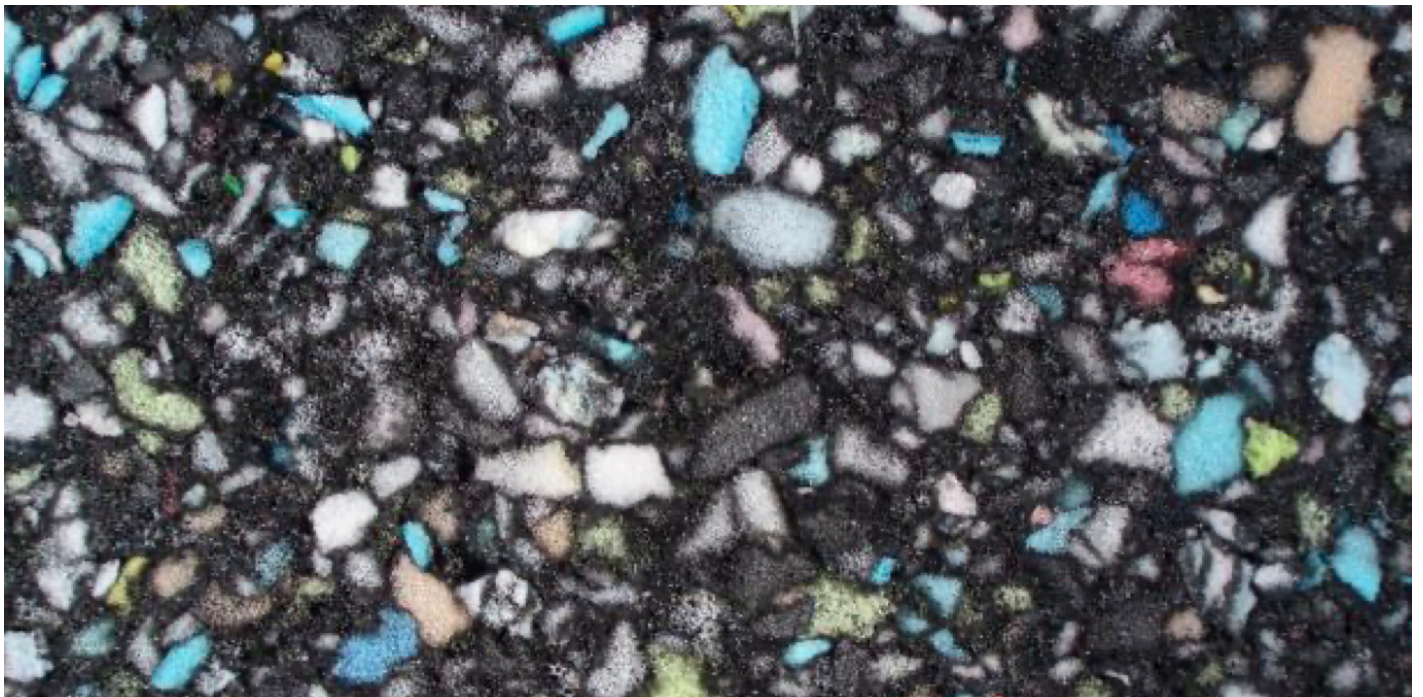

Annexes ROS/BOS

kettal

ROS Hub

ROS Wireless Hub

The ROS Hub offered by Kettal and its selected Technology partners provides a connection point for ROS devices such as PowPak wireless dimming and switching modules, Pico remote controls, Radio Powr Savr occupancy sensors, and daylight sensors. For a complete list of compatible devices, see the last page of this document.

For more information on the ROS hub, including training materials, design information and software updates.

- Can be easily programmed with any Wi-Fi enabled iOS® or Android® compatible device using the free app (available for download from the App Store or Google Play®) or by using web-based software.

- iOS® and Android® Apps – Helper apps act as an intermediary between ROS systems and the Cloud without the need of a permanent internet connection. It connects to hubs when on-site and passes data back and forth when the smart device reconnects to the Internet. / ROSPrivacyNotice for more about this data.

- Registration of jobs / users for extended warranty.
- Manage multiple jobs with contacts and job info.
- Invite facility users to have access to hubs / job.
- Automatically send hand-off documentation personalized to your firm to facility management team. Including programming user guide, online “How-to” videos, and support number.
- Connection to hub browser user interface for setup. Normal web browser still works and the app is not required.
- Connection to hub browser dashboard for control and monitor. Normal web browser still works and the app is not required.
- Backup the database to the Cloud for hub replacement.
- Download reports that list the inventory of hubs and devices commissioned in your job.

- Communicates with controls on a floor using wireless Clear Connect technology.

- Distributed system architecture.

- Wireless sensors and controls must be located within 9 m of the associated device.

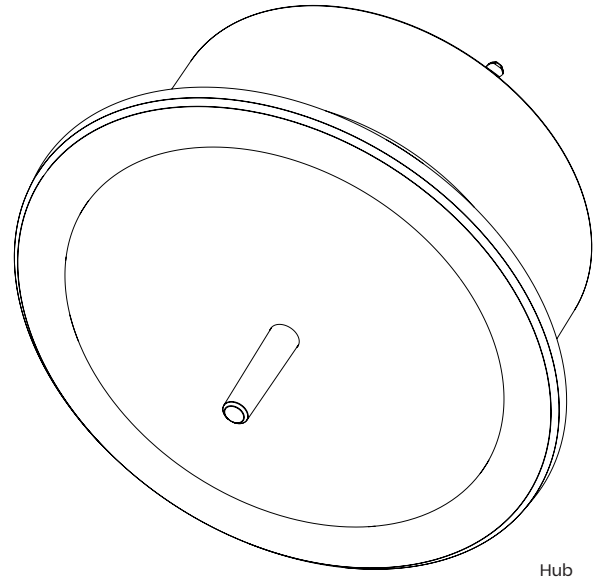

- Supports timeclock events based on both sunrise and sunset or fixed time-of-day.
- Timeclock events can control individual devices, areas, or groups of areas.
- * Note: This feature is not available once a hub is paired with a ROS Vue server.
- Uses RF signal strength measurements to find devices nearby for quick association and programming without having to climb ladders.
- Dashboard of current status for control and monitoring of the system. Also shows current energy usage.
- Integrated multi-color LED provides feedback on what mode the hub is in.
- Connects directly to any smartphone, tablet or computer using built in Wi-Fi. 2.4 GHz 802.11b / g using WPA2 Security.

ROS Hub

Features (continued)

- Ethernet 10 / 100 Mbps connection for:
 - Native BACnet® / IP (see P/N 369996 at www..com for PIC Statement) integration into Building Management Systems (HKS-2-XX only). The ROS Hub has been tested by BACnet® Testing Laboratories (BTL) and is certified to comply with all necessary interoperability requirements.
 - Network multiple ROS hubs together as an independent system or as part of an existing building network.
 - Native OpenADR® support, to manage Automatic Demand Response / Load Shed events dictated by a utility company.
 - Each ROS hub hosts a unique virtual BACnet® network. As such, each ROS hub requires a unique BACnet® network number.
- Firmware upgradable for future features and security patches.
- Password protected access.
- Flush-mount or surface-mount options available.
- Supported on most devices that use an HTML5 compliant browser (iOS®, Android®, Windows®, Mac®).
- Required browsers are Google® Chrome® and Safari®.
- Supports HTTPS.
- Recommended configurations for smart devices:

| Device | OS Version |
|-------------------------------------------------------------------|-----------------------|
| iPhone 6, iPhone 6 plus or newer | iOS® 11 or later |
| Supported on most Android® devices running Android® 6.0 or later. | Android® 6.0 or later |

- Daylighting Setpoint Tweaking – If the lights are too bright or too dim while using daylighting, adjust the settings in real time from a smart device to alter the setpoint for the light level that is maintained between natural and electric light. Older devices (released prior to September 2017) can be adjusted but may take a minute to reach the desired level because of a slow fade. New devices will respond immediately.

- Daylighting-to-Low-End or Daylighting-to-Off - The ROS system will allow the user to select either daylighting-to-low-end or daylight-to-off on an area by area basis.
 - * Requires ROS hub software 01.08 or higher.
- Customer Supplied Security Certificates
 - Provides customers the ability to load their own authentication certificates for their specific domain.
 - Provides customers using the ROS hub application to use secure browser communications without receiving any authentication warnings due to the self-signed certificates that are shipped with the hubs.
 - Requires ROS hub software 01.08 or higher.
- Timeclock Occupancy Sensor Settings Changes
 - Requires devices shipped after September 2017. Devices shipped prior to that date will be displayed as "unsupported" in the software UI. Allows timeclock events to change the behavior of occupancy settings based on time of day. For example, change the unoccupied level of corridors / hallways from 25% during the day, and off at night. The following settings can be changed:
 - Occupied Level – The level the lights go to when occupied. Changes are not applied immediately to currently occupied spaces, but will change the next time the space goes occupied to minimize distraction.
 - Unoccupied Level – The level the lights go to when unoccupied. Changes are applied immediately to spaces not currently occupied.
 - Enable / Disable Occupancy – Change whether devices will respond to the occupancy sensor.
 - Timeout of the sensors (requires FC-VSENSOR). LRF2 sensors still require this setting to be set on the sensor.
- 365-day schedulable timeclock with exceptions for holidays.
 - Allows scheduling events 10 years in advance.
 - Set recurring events with exceptions on holidays.
 - Allows scheduling events on specific day of the year.

ROS Hub

Features (continued)

- Provides calculated energy data for PowPak modules.
- Create and edit areas.
- Tune area light levels by trimming the high-end and low-end output.
- Adjust occupancy settings. Create occupancy groups.
- User can choose to extend the RF range of up to 15 of the total Pico remote controls per ROS hub. These remotes will be able to control any devices within the 22 m range.
- RF range of occupancy sensors can be extended for up to 14 areas per ROS hub. In a range-extended area, an occupancy sensor can control any device in that area, regardless of distance between sensor and device. Requires ROS hub software 01.09 or higher.
- Configurable Fade Time
 - Up to 90 minutes for timeclock events and scenes.
 - Up to 90 seconds for Pico remote control programming.
 - o Fade time may differ between buttons on the same Pico remote control.
 - o Single fade time applies to all programming for a button.
- Automatic Demand Response / Load Shed
 - Load Shedding will physically dim the lights to a programmable level.
 - OpenADRR 2.0b compliant (requires ROS hub software 01.09 or higher).
 - May be enabled (or disabled) via any of the following methods:
 - o The first contact closure input (CCI 1)
 - o BACnet R integration
 - o OpenADR R integration
 - OpenADRR requires access to utility companies over the Internet, so the hub must be connected via Ethernet to use OpenADRR.
- Alerts
 - View run-time issues which may prevent devices from operating as expected, such as low batteries or missing devices.
- API Integration
 - To integrate with third-party devices, systems, and software, RESTful APIs are available over the Ethernet.
- Scenes
 - Scenes can control individual devices, areas, or groups of areas on demand.
 - May be activated via any of the following methods:
 - o The second contact closure input (CCI 2)
 - o API integration
 - o Manual activation in the app
 - Maximum of 50 scenes are supported.
 - Requires ROS hub software 01.13 or higher.
- Programmable CCI
 - The second contact closure input (CCI 2) can be programmed to activate a scene.
 - Scene activation
 - o Set a scene to activate using second contact closure input (CCI 2) on the ROS hub.
 - Requires ROS hub software 01.13 or higher
- Occupancy Dependency
 - Occupancy sensors in one room/area can control devices in other rooms/areas.
 - Radio Powr Savr occupancy sensors and Maestro Wireless 0–10 V-dimmers and switches with sensor only.
 - Requires ROS hub software 01.14 or higher.

ROS Hub

Specifications

Regulatory Approvals

- CE (European Union)

Power / Performance

- Input to power supply:
220 – 240 V~ 50 / 60 Hz 0.6 A
- Input to ROS hub:
24 V- 350 mA

System Limits

- HKS-1, HKS-2 support up to 700 Wireless devices. HKS-0 supports 75 Wireless devices.
- Any given load device can be controlled by 10 occupancy sensors, 10 Pico remote controls and 1 daylight sensor (Pico remote controls and sensors must be located within 9 m of the load device they are controlling).

Metal Ceiling Mounting

- Metal ceiling grids must have a ≥ 3 mm gap of non-metal material which extends the entire length of the tile on at least one edge. This is often achieved by foam spacers that are used to prevent tile-to-tile rattling.
- Metal ceiling grids which are continuous (with no gap) or those that are interlocked, must have a total surface area that is less than 81 m² for each section. The overall space can be larger as long as there are non-metal sections bordering or intersecting the metal sections.
- Do not install the ROS hub above metal ceilings or tiles with a metal backing.

Mounting

- Use surface-mount version for mounting to a hard or cement ceiling.
- Power supply mounts to a -supplied US-style 101.6 mm x 101.6 mm (4 in x 4 in) junction box.
- Power supply must be mounted within 30 m of the ROS hub. Wiring should be 0.2 mm² to 2.5 mm² (24 AWG to 12 AWG).

Environment

- For indoor use only.
- 0 °C to 40 °C.
- Relative humidity less than 90% non-condensing.

Contact Closure Input Terminals

- First contact closure input (CCI 1) is to be used for initiating load shed only.
- The second contact closure input (CCI 2) may be programmed to activate a scene.
If activating a scene, a "deactivation" behavior may be set in the scene in order to set two behaviors for the one input.
- Accepts only maintained inputs.
- Off-state leakage current must be less than 100 μ A.
- Open circuit voltage: 24 V- maximum.
- Input wiring: 0.2 mm² to 2.5 mm² (24 AWG to 12 AWG). • Contact Closure Inputs on multiple hubs can be wired in parallel. DO NOT wire inputs in parallel with other equipment as it can cause the inputs on either of the devices to falsely trigger.
- Up to 4 hubs in parallel.
- To ensure proper operation of Contact Closure Inputs, a PS-K-20W-240 power supply may not be used to provide power to more than one hub.
- Inputs must be dry contact closure, solid state, open collector, or active-low (NPN) / active high (PNP) output.
 - Open collector NPN or active-low on-state voltage must be less than 2 V and sink 3.0 mA.
 - Open collector PNP or active-high on-state voltage must be greater than 12 V and source 3.0 mA.

Programming

The ROS Hub is meant to be permanently installed. It is not intended to be used as a programming tool that can be removed from the site after commissioning. Various ROS system features are dependent on the hub for proper functionality. In addition, users and other maintainers will be forced to recommission the entire system in order to make simple changes or additions if the hub is not installed on-site as part of the commissioned system.

Warranty

- 2 year limited warranty. The customer can register the product to increase the warranty period from 2 year to 5 years.

ROS Hub

Range Diagrams

All wireless devices to be associated to the ROS hub must be within 22 m of the ROS hub and must be on the same floor as the ROS hub.

Note: ROS hubs should be mounted greater than 3 m apart on the same floor.

Note: requires that the ROS hub not be installed above metal ceilings or tiles with a metal backing.

Note: A corporate Wi-Fi network can interfere with the Wi-Fi on the ROS hub. Where a corporate Wi-Fi network exists, it is recommended to do the following:

- Connect the ROS hub to the corporate network using the Ethernet connection on the hub and disable Wi-Fi on the hub.

Note: ROS hubs should be mounted greater than 3 m from a Wi-Fi router or access point.

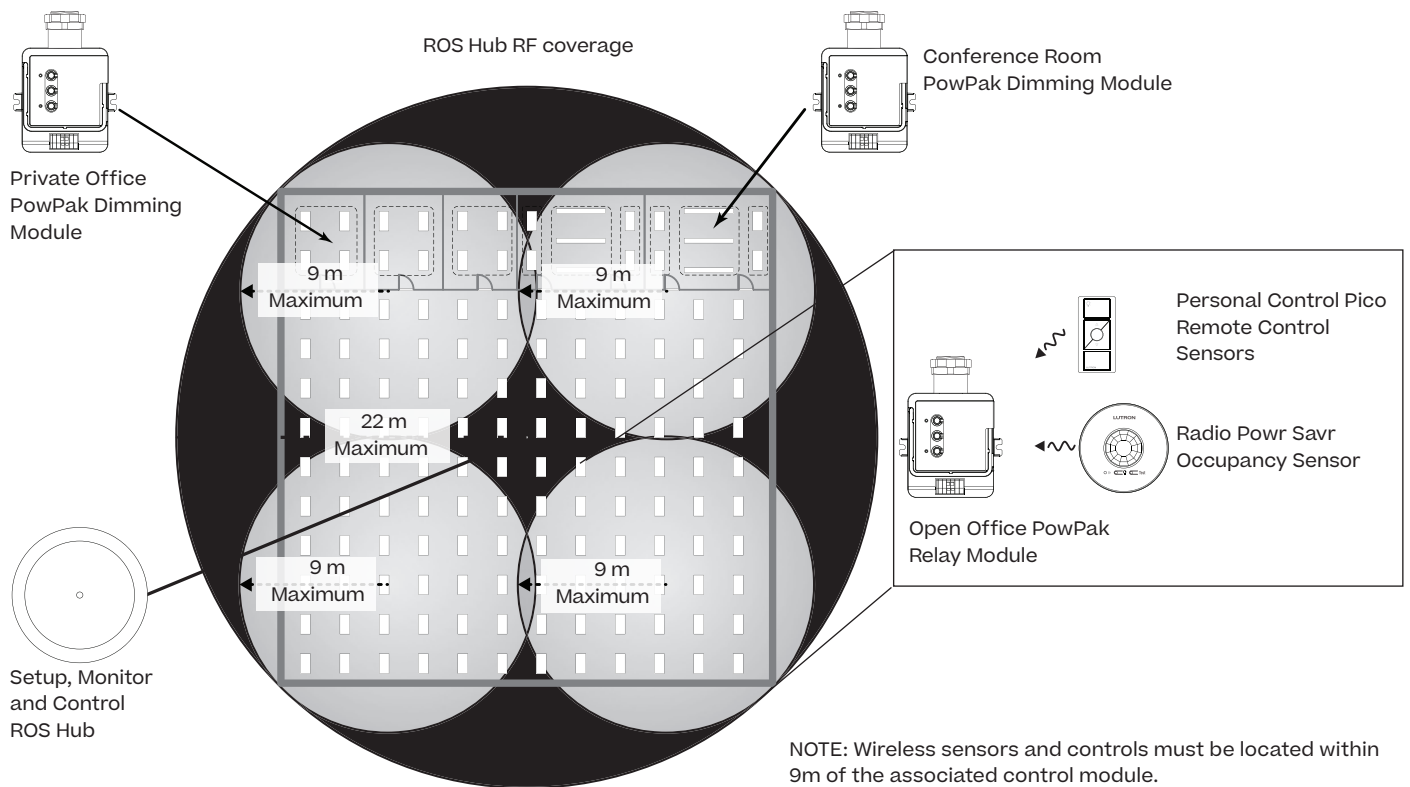

Range with multiple ROS hubs

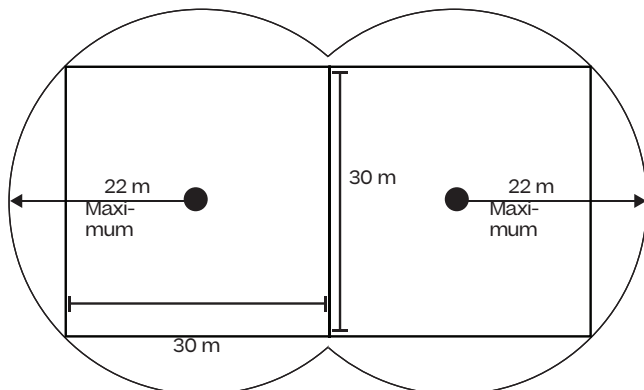

- Metal ceiling grids must have a > 3 mm gap of non-metal material which extends the entire length of the tile on at least one edge. This is often achieved by foam spacers that are used to prevent tile-to-tile rattling.

- Metal ceiling grids which are continuous (with no gap) or those that are interlocked, must have a total surface area that is less than 81 m² for each section. The overall space can be larger as long as there are non-metal sections bordering or intersecting the metal sections.

ROS Hub

Wiring and Mounting

Product Overview
(Flush-mount adapter)

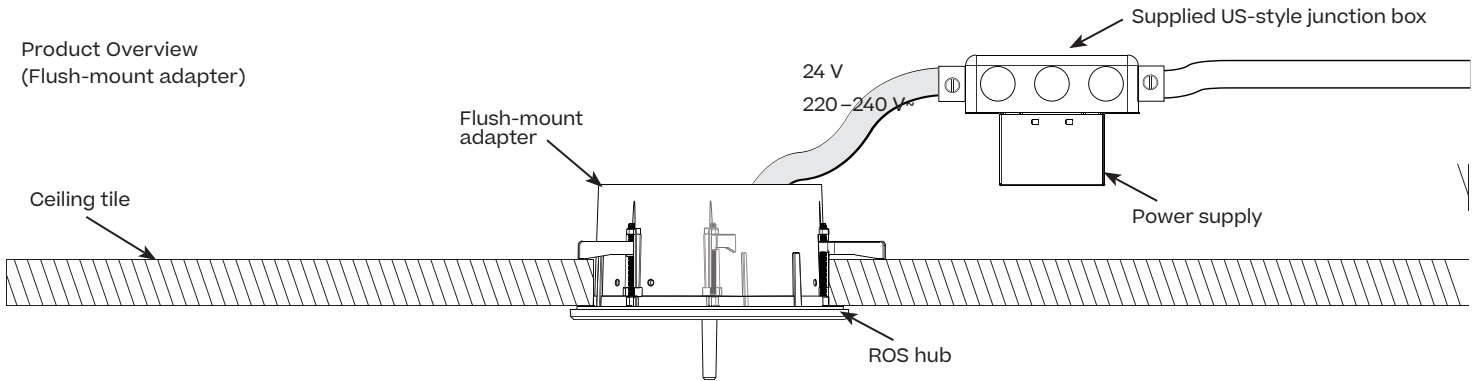

Product Overview
(Surface-mount adapter)

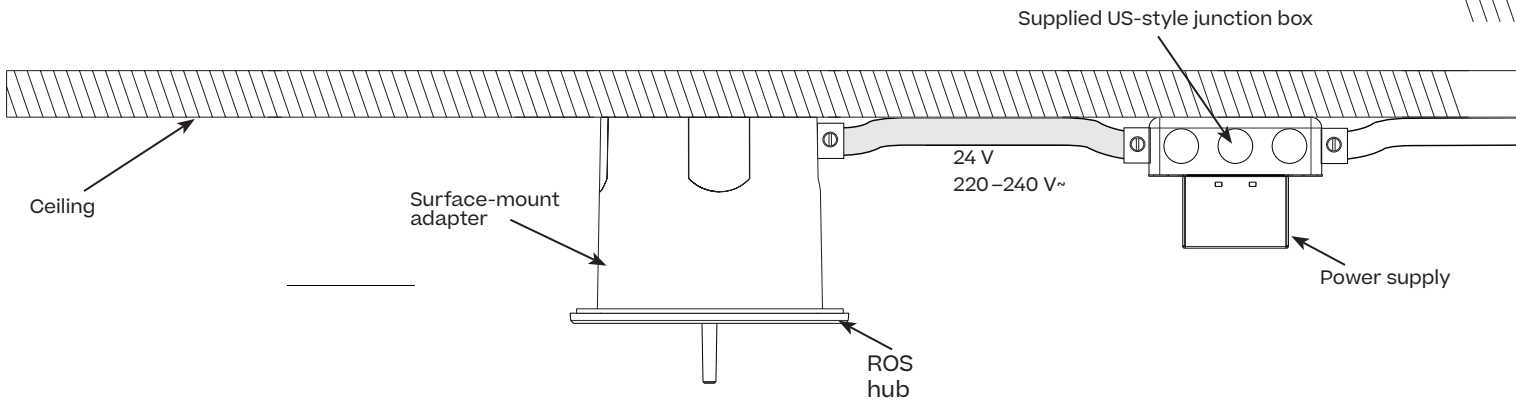

ROS Hub

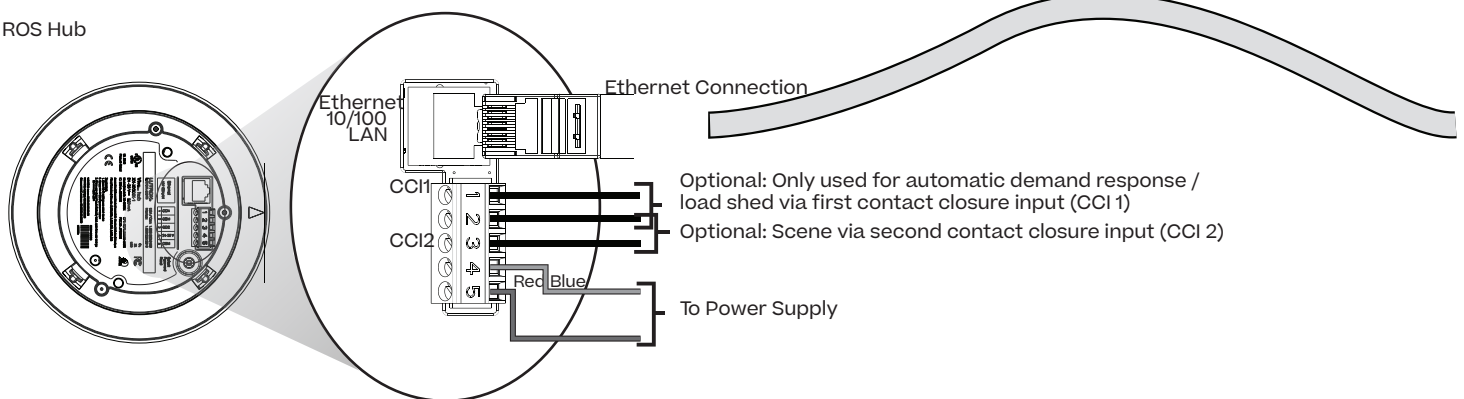

ROS Hub

ROS Security Statement takes the security of the ROS Lighting Control System very seriously. The ROS Lighting Control System has been designed and engineered with attention to security since its inception. has engaged security experts and independent testing firms throughout the entire development of the ROS Lighting Control System. is committed to security and continuous improvement throughout the ROS product lifecycle. The ROS Lighting Control System uses a multi-tiered approach to security.

They include:

1. An architecture that isolates the wired Ethernet network from the wireless network, which strictly limits the possibility of the ROS Wi-Fi being used to access the corporate network and gain confidential information
2. A distributed security architecture with each hub having its own unique keys that would limit any potential breach to only a small area of the system
3. Multiple levels of password protection (Wi-Fi network and the hubs themselves), with built-in rules that force the user to enter a strong password
4. ISO-recommended best practices including salting and SCrypt for securely storing usernames and passwords
5. AES 128-bit encryption for network communications
6. HTTPS (TLS 1.2) protocol for securing connections to the hub over the wired network
7. WPA2 technology for securing connections to the hub over the Wi-Fi network
8. Azure provided encryption-at-rest technologies

The ROS hub can be deployed in one of two ways:

Dedicated Network

Connected to the corporate IT network via Ethernet. The ROS hub must be connected via Ethernet to access certain features such as BACnet® for BMS integration or OpenADRR integration. advises following best practices in this instance, including separating the business information network and the building infrastructure network. Use of a VLAN or physically separated networks is recommended for secure deployment.

Dedicated Network Deployment

The ROS hub is not connected to the building network. Wi-Fi is used to connect to a smart device such as a phone, tablet, or PC for commissioning and configuration only. The ROS hub serves web pages for setup and maintenance via a password-protected connection. The Wi-Fi SSID can be set to not broadcast. The ROS hub Wi-Fi may be disabled if desired.

Corporate IT Network Deployment

The ROS hub may be deployed with a fixed Ethernet IP address or served over DHCP. Once the IT network is operational, the ROS hub will serve password-protected web pages for access and maintenance. The ROS hub Wi-Fi may be disabled if desired. The ROS hub reserves the IP subnet 192.168.3.0/24 for its Wi-Fi, so the hub cannot be assigned an Ethernet IP address in that range.

The ROS hub acts as a Wi-Fi access point purely for the configuration and commissioning of the ROS system. It is not a substitute for your building's normal Wi-Fi access point. The ROS hub does not act as a bridge between wireless and wired networks.

It is strongly recommended that local IT security professionals be involved with the network configuration and set-up to ensure the installation meets their security needs.

ROS Hub

Security 1

Dedicated Network
Wi-Fi Only

Ports used

- No IT configuration needed

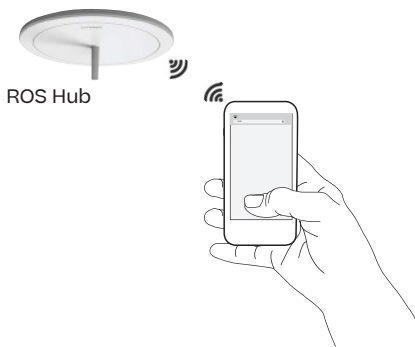

Corporate Network
Single Hub

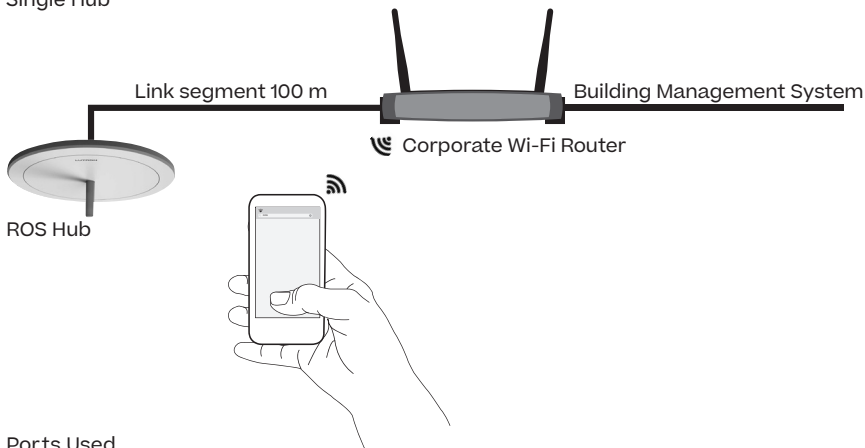

Ports Used

| Traffic | Port | Type | Connection | Description |
|----------|----------------------|------|-------------------------|---------------------------------------------------------------|
| Outbound | 47808 (configurable) | UDP | Ethernet | Used for BACnet® integration into Building Management Systems |
| | 80 | TCP | | Used to discover the ROS hub when mDNS is not available |
| | 5353 | UDP | Ethernet | Used to discover the ROS hub via mDNS |
| | Configurable | TCP | Ethernet | Used for OpenADRR. Specified by utility company |
| Inbound | 443 | TCP | Both Ethernet and Wi-Fi | Used to serve user interface to smart device |
| | 80 | TCP | | Used by other ROS hubs to proxy |
| | 8081 | TCP | Ethernet | Used for local LEAP connections to integrations and ROS Vue |
| | 8083 | TCP | Ethernet | Used for local LAP connections to integrations and ROS Vue |
| | 8444 | TCP | Ethernet | Used to communicate with the ROS Vue server |
| | 47808 (configurable) | UDP | Ethernet | Used for BACnet® integration into Building Management Systems |
| | 5353 | UDP | Ethernet | Used to discover the ROS hub via mDNS |

ROS Hub

Security 1 (continued)

Corporate Network
Multiple Hubs

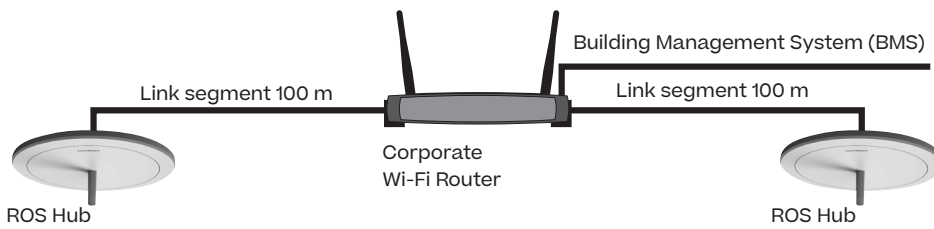

Ports Used

| Traffic | Port | Type | Connection | Description |
|----------|----------------------|------|-------------------------|---------------------------------------------------------------|
| Outbound | 47808 (configurable) | UDP | Ethernet | Used for BACnet® integration into Building Management Systems |
| | 80 | TCP | | Used to discover the ROS hub when mDNS is not available |
| | 5353 | UDP | Ethernet | Used to discover the ROS hub via mDNS |
| | Configurable | TCP | Ethernet | Used for OpenADRR. Specified by utility company |
| Inbound | 443 | TCP | Both Ethernet and Wi-Fi | Used to serve user interface to smart device |
| | 80 | TCP | | Used by other ROS hubs to proxy |
| | 8081 | TCP | Ethernet | Used for local LEAP connections to integrations and ROS Vue |
| | 8083 | TCP | Ethernet | Used for local LAP connections to integrations and ROS Vue |
| | 8444 | TCP | Ethernet | Used to communicate with the ROS Vue server |
| | 47808 (configurable) | UDP | Ethernet | Used for BACnet® integration into Building Management Systems |
| | 5353 | UDP | Ethernet | Used to discover the ROS hub via mDNS |

Inter-Hub Link Wiring

- The inter-hub wiring is rated IEC PELV.
- Wiring distance for any single link segment is 100 m max; use third-party Ethernet switches for longer distances.
- Up to 64 hubs can be networked together.
- Up to 100 hubs can be networked together when ROS Vue is used.
- Hubs communicate over the inter-hub link using multicast UDP or TCP; a dedicated network is recommended but not required.
- The Wi-Fi access port cannot be used to create an ad hoc network for use as the inter-hub communication link.

ROS RF

Rather than cast our network decision as a binary choice, we built Clear Connect Type X to be a complementary solution to our 434 MHz 15.231-based platform, now designated Clear Connect Type A.

Clear Connect is our partner overall standard for ultra-reliable wireless devices, with different sub types, Type A and Type X, for different application specific implementations. To meet the Clear Connect standard our products go through rigorous testing and certification. Our Clear Connect Type A (434 MHz, FCC 15.231-based) solution will remain an excellent solution for low-density, non-uniform networks with both powered and battery-operated devices. Complementing this is our Clear Connect Type X (2.4 GHz, IEEE 802.15.4-based) solution, designed for dense deployments of small form factor, high performance lighting with more sophisticated features.

FCC 15.231: An overview

- Devices are relatively low power (fractions of a watt). This reduces the possibility of interference between adjacent systems and eases a product's power supply requirements.
- Devices may not transmit continuously. Generally speaking, all activity is driven by user action (like pressing a button), which further reduces the likelihood of interference.
- Devices may not poll or generate periodic transmissions. There is a 5-second maximum event time after pressing a button.
- Devices in this band include garage door openers, security sensors, and car key fobs.

ROS RF

868MHz band in Europe and UK

The leader in light control

- In business over 55 years
- Global organization
- 24/7 technical support
- Focus on light, shade, temperature and energy control
- Industry leader expanding the market with trade and consumer campaigns
- Industry leader who is providing programs to develop your business

RF Experience

- Pioneered RF automation category
- Millions of wireless devices sold
- More than two decades of industry-leading wireless design, production, sales, and installation
- Many diverse product lines across residential, commercial, North American, and international markets

RF Technology

- Numerous RF-specific patents
- Fast group or preset commands
- Unique identifiers allow multiple devices and multiple systems to be used within proximity to one another without interference.

Depth

- Load types: LED, ELV, MLV, FL, halogen, incandescent
- World's most advanced shading and temperature solutions
- Works in installations with and without neutral wires in the backbox
- Dimming and switching
- Wall-mounted and tabletop dimmers and keypads
- Numerous choices for aesthetic styles, colors, and finishes
- Easy and reliable integration (mobile apps, Ethernet, cloud services, RS232, IR, CCI's, CCO's)

Quality

- Recognized industry leader
- ISO 9001:2015 certified
- 100% end-of-line testing
- 24/7 global tech support

Product Description

BACnet IP is embedded in the ROS hub. There are two types of BACnet devices available in ROS:

ROS hubs and area devices. The ROS hubs are main BACnet devices; typically, one to two ROS hubs per floor of the building. The area devices are virtual BACnet devices of the ROS hub, typically one per room of the building. It is normal to have multiple ROS hubs and area virtual devices in a project.

BACnet Interoperability Building Blocks Supported (Annex K):

| | | |
|-------------|-------------------|-----------------------------------------|
| K.1.2 BIBB | Data Sharing | ReadProperty-B (DS-RP-B) |
| K.1.4 BIBB | Data Sharing | ReadPropertyMultiple-B (DS-RPM-B) |
| K.1.8 BIBB | Data Sharing | WriteProperty-B (DS-WP-B) |
| K.1.10 BIBB | Data Sharing | WritePropertyMultiple-B (DS-WPM-B) |
| K.1.12 BIBB | Data Sharing | COV-B (DS-COV-B) |
| K.5.2 BIBB | Device Management | DynamicDeviceBinding-B (DM-DDB-B) |
| K.5.4 BIBB | Device Management | DynamicObjectBinding-B (DM-DOB-B) |
| K.5.6 BIBB | Device Management | DeviceCommunicationControl-B (DM-DCC-B) |

BACnet Standardized Device Profile (Annex L):

BACnet Application Specific Controller (B-ASC)

Segmentation Capability:

Segmented requests supported? No.

Window Size: n/a

Segmented responses supported? No. Window Size: n/a

Non-Standard Application Services:

Non-standard application services are not supported.



BACnet is a registered trademark of ASHRAE. ASHRAE does not endorse, approve or test products for compliance with ASHRAE standards. Compliance of listed products to the requirements of ASHRAE Standard 135 is the responsibility of BACnet International (BI). BTL is a registered trademark of BI.

Standard Object Types Supported:

Device

1. Dynamically creatable using BACnet CreateObject service? No.
2. Dynamically deletable using BACnet DeleteObject service? No.
3. List of optional properties supported: Active_COV_Subscriptions, Description, Location, Profile_Name.
4. List of all properties that are writable where not otherwise required by this standard: None.
5. List of proprietary properties: None.
6. List of any property value range restrictions: None.

Analog Value

1. Dynamically creatable using the BACnet CreateObject service? No.
2. Dynamically deletable using BACnet DeleteObject service? No.
3. List of optional properties supported: COV_Increment (See Table for objects that support this property).
4. List of all properties that are writable where not otherwise required by this standard: None.
5. List of proprietary properties: None.
6. List of any property value range restrictions: See Table.

Binary Value

1. Dynamically creatable using BACnet CreateObject service? No.
2. Dynamically deletable using BACnet DeleteObject service? No.
3. List of optional properties supported: Active_Text, Inactive_Text.
4. List of all properties that are writable where not otherwise required by this standard: None.
5. List of proprietary properties: None.
6. List of any property value range restrictions: See Table.

Multi-State Value

1. Dynamically creatable using BACnet CreateObject service? No.
2. Dynamically deletable using BACnet DeleteObject service? No.
3. List of optional properties supported: State_Text.
4. List of all properties that are writable where not otherwise required by this standard: None.
5. List of proprietary properties: None.
6. List of any property value range restrictions: See Table.

Data Link Layer Options:

Other: These devices are virtual devices and are represented by a six octet address equal to the 48-bit device instance of the virtual device.

Device Address Binding:

Is static device binding supported? No.

Networking Options:

BACnet / IP Annex J — non-BBMD functionality; the ROS is able to register as a foreign device. The ROS hub is able to initiate original-broadcast-NPDU.

Character Sets Supported:

Indicating support for multiple character sets does not imply that they can all be supported simultaneously.

- UTF-8

BACnet Routing:

The ROS hub is a BACnet virtual router. All of the virtual area devices are routed through the main ROS hub.

BOS

| Object Name | Type | Instance | Read | Write | COV | Units | Min PV | Max PV | Inactive Text (0) | Active Text (1) | State Text (Multi-State) | Notes |
|---------------------------|--------|-------------|------|-------|-----|-------|--------|--------|-------------------|-----------------|--------------------------|----------------------------------------------------------------------------------------------------------------------------------------------------------------------------------------------------------------------------------------------------------------------------------------------------------------------------------------------------------------------------------------------------------------------------------------------------------------------------------------------------------------------------------------|
| {SystemName} / {Instance} | DEVICE | 22 bit GUID | X | — | — | — | — | — | — | — | — | The System Name is the logical name of one of the ROS hubs that typically corresponds to a physical portion of the building such as a floor. The Instance is the same as the unique Device ID assigned to each ROS hub. |
| Master Load shed Enabled | BV | 2 | X | X | X | — | 0 | 1 | Disabled | Enabled | — | This value determines whether all of the areas in the ROS sub-system are being controlled via load shedding. When this value is set to Enabled, for all areas in the hub that have load shed allowed, any dimmable lights in each area that are turned on will have their light level reduced by the percentage specified in the Load shed Goal value. The specified switched loads will turn off. When Disabled, the lights will return to their previous level and the specified switched loads will return to their previous state. |

| Object Name | Type | Instance | Read | Write | COV | Units | Min PV | Max PV | Inactive Text (0) | Active Text (1) | State Text (Multi-State) | Notes |
|-------------------------|--------|-------------|------|-------|-----|-------|--------|--------|-------------------|-----------------|--------------------------|-----------------------------------------------------------------------------------------------------------------------------------------------------------------------------------------------------------------------------------------------------------------------------------------------------------------------------------------------------------------------------------------------------------------------------------------------------------------|
| {AreaName} / {Instance} | DEVICE | 22 bit GUID | X | — | — | — | — | — | — | — | — | The Area Name is the logical name of of the ROS hub that typically corresponds to a physical location in a building. The Instance is the same as the unique Device ID assigned to each area. |
| Lighting Level | AV | 2 | X | X | X | % | 0 | 100 | — | — | — | The intensity level of all lighting fixtures in the area. The light level will be an analog value between 0% and 100%. If the lighting fixtures in the area are at different light levels, this value will be set to the level of the highest intensity in that area. This will apply to both switched and dimmed lighting fixtures. If a non-zero level is written switched lighting fixtures will turn on and dimmed lighting fixtures will go to that level. |
| Lighting State if any | BV | 3 | X | X | X | — | 0 | 1 | Off | On | — | The Lighting State will be On of the lighting fixtures in the area are in the on state; if all lighting fixtures are off, the Lighting State will be set to Off. When written with On, it will turn all dimmable lighting loads to 100% and turn all switched lighting loads on. When written with Off, it will turn all lighting loads off. |

AV = Analog-Value, BV = Binary-Value, MSV = Multi-State-Value

{Area Name} / {SystemName} is a text string defined in the ROS system configuration software

{Instance} is a number defined in the ROS system configuration software that is equal to the {Base} number + unique Device ID assigned to each area. PV = Present-Value

BOS

| Object Name | Type | Instance | Read | Write | COV | Units | Min PV | Max PV | Inactive Text (0) | Active Text (1) | State Text (Multi-State) | Notes |
|-------------------|------|----------|------|-------|-----|-------|--------|--------|-------------------|-----------------|-----------------------------------------|---------------------------------------------------------------------------------------------------------------------------------------------------------------------------------------------------------------------------------------------------------------------------------------------------------------------|
| Disable Occupancy | BV | 7 | X | X | X | — | 0 | 1 | False | True | — | When set to True, occupancy sensors will not affect the lights in the area. When set to False, occupancy sensors will affect the lights in the area as programmed. |
| Occupancy State | MSV | 8 | X | — | X | — | 1 | 4 | — | — | 1=Unoccupied 2=Occupied 4=Unknown | A read-only property indicates the occupancy of the entire area. Occupied means that at least one sensor in the area is indicating occupancy. Unoccupied means that all of the sensors in the area are indicating unoccupied. Unknown indicates that not all of the sensors in the area have reported their status. |
| Unoccupied Level | AV | 9 | X | X | X | % | 0 | 100 | — | — | — | The light level to which the dimmed lights in the area will be set when an area transitions to unoccupied. |
| Occupied Level | AV | 10 | X | X | X | % | 0 | 100 | — | — | — | The light level to which the dimmed lights in the area will be set when an area transitions to occupied. |
| Load shed Allowed | BV | 12 | X | X | X | — | 0 | 1 | No | Yes | — | When Load shed Allowed is set to YES, this area will be affected when Load shed is Enabled. When set to NO, this area will not be affected when Load shed is Enabled. |
| Load shed Goal | AV | 13 | X | X | X | % | 0 | 90 | — | — | — | When Load shed is enabled and Load shed Allowed is set to YES, the light level will be reduced by the percentage specified. Range: 0% to 90% |

AV = Analog-Value
 BV = Binary-Value
 MSV = Multi-State-Value
 PV = Present-Value

BOS

| Object Name | Type | Instance | Read | Write | COV | Units | Min PV | Max PV | Inactive Text (0) | Active Text (1) | State Text (Multi-State) | Notes |
|----------------|------|----------|------|-------|-----|-------|--------|--------|-------------------|-----------------|--------------------------------------------------------------------------------------------------------------------------------------------------|-----------------------------------------------------------------------------------------------------------------------------------------------------------------------------------------------------------------------------------------------------------------------------------------------------------------------------------------------------------------------------------------------------------------------------------------------------------------------------------------------------------------------------------------------------------------------------------------------------------------------------------------------------------------------------------------------------------------------------------------------------------------------------------------------------------------------------------------|
| Occupancy Mode | MSV | 14 | X | X | X | N/A | 2 | 5 | — | — | 2= Automatic ON, Automatic OFF (Read-Write) 3= Manual ON, Automatic OFF (Read-Write) 4= Not Applicable (Read-Only) 5= Mixed (Read-Only) | Determines the way that the occupancy sensors control the lights. When set to Automatic ON and Automatic OFF, the sensors will set lights to their occupied level when occupied and to their unoccupied level when unoccupied. When set to Manual ON and Automatic OFF, the sensors will set lights to the unoccupied level only when an area changes to unoccupied. Not Applicable means that the area is not controlled by occupancy. Mixed means that the zones in the area have been configured as a combination of "Automatic ON and Automatic OFF" and "Manual ON and Automatic OFF" modes. NOTES: 1. States Not Applicable and Mixed are read-only states. Writes with those states will return a value out of range error. 2. State value 1 is not used and reserved. Writing 1 results in a value out of range error. |
| Total Power | AV | 18 | X | — | X | watts | 0 | none | — | — | — | A calculated /measured value that indicates the total instantaneous power consumption for all of the lighting loads in the area. |
| Maximum Power | AV | 19 | X | — | X | watts | 0 | none | — | — | — | The maximum connected lighting load of the area. This value is the maximum value that Total Power can achieve. Maximum Power minus Total Power equals the power being saved. This value typically does not change. |

AV = Analog-Value, BV = Binary-Value
MSV = Multi-State-Value
PV = Present-Value