

Phonebooth,  
by Kettal Studio

**kettal**

# Description

Designer  
Kettal Studio

Collection  
Phonebooth

Privacy can be hard to come by in large open offices. Our Phone booth O allows your employees to make calls or hold video conferences with unbroken focus and without disturbing the rest of the team. The Phone booth O design is inspired by the traditional telephone booth. They are an elegant yet functional solution for your office. Comfortable and echo-free, the Phone booth O is also simple to install.

|    | Height      | Width       | Length      |
|----|-------------|-------------|-------------|
| S  | 240 / 94,5" | 117 / 46    | 117 / 46    |
| L  | 240 / 94,5" | 217 / 85,4" | 117 / 46    |
| XL | 240 / 94,5" | 217 / 85,4" | 217 / 85,4" |

Bespoke sizes on demand



# Isometric view

Designer  
Kettal Studio

Collection  
Phonebooth

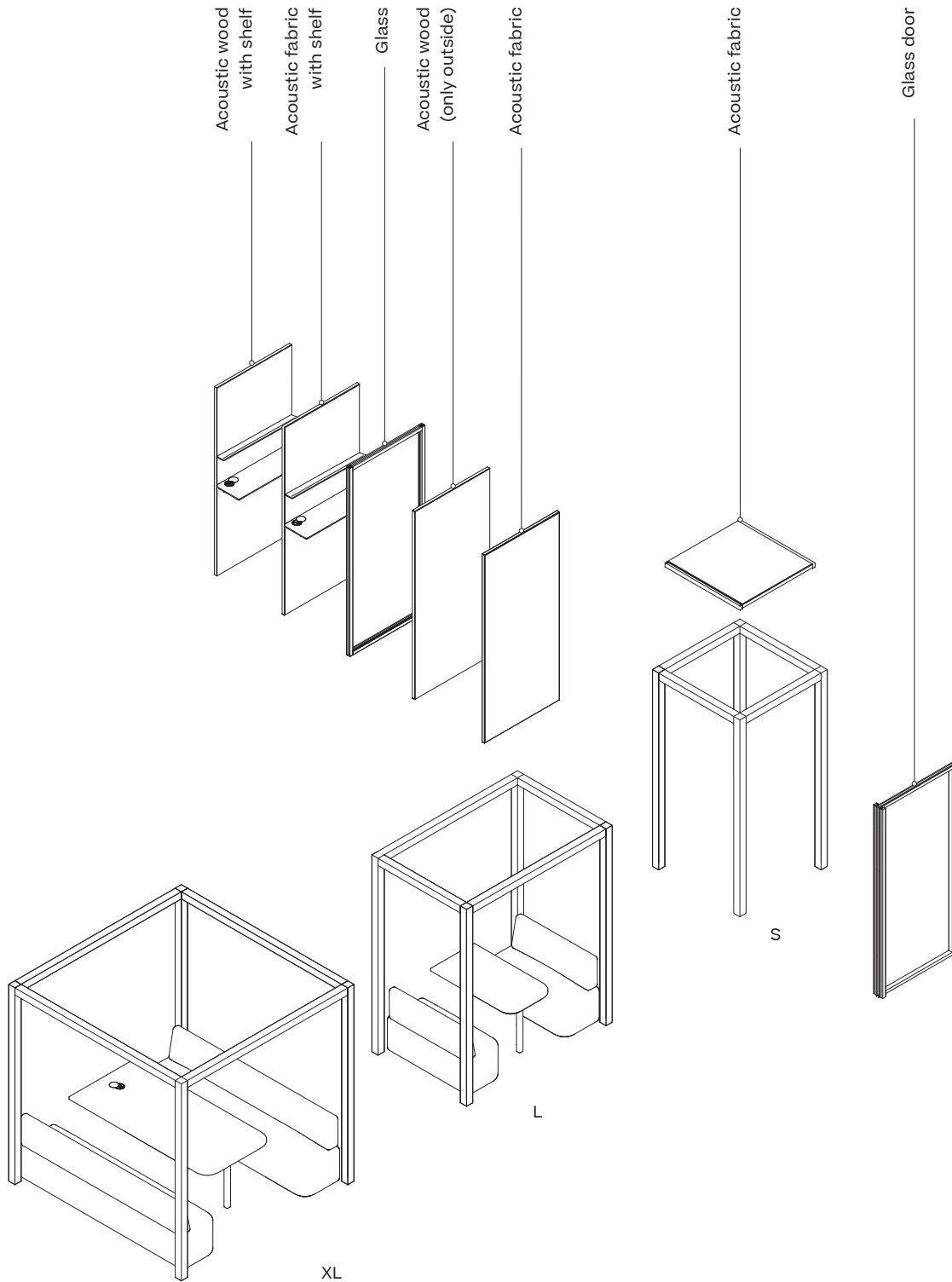

# Features

Designer  
Kettal Studio

Collection  
Phonebooth



Table with Plug / USB- A / USB-C



Shelf + Led light + PIR



LED track curtain



Handicap flooring, pivoting door



Plug and play

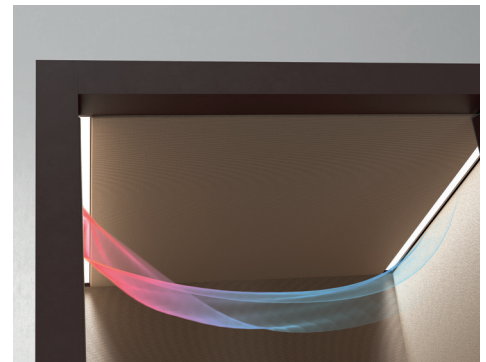

Ventilation system

# Phonebooth S

Designer  
Kettal Studio

Collection  
Phonebooth

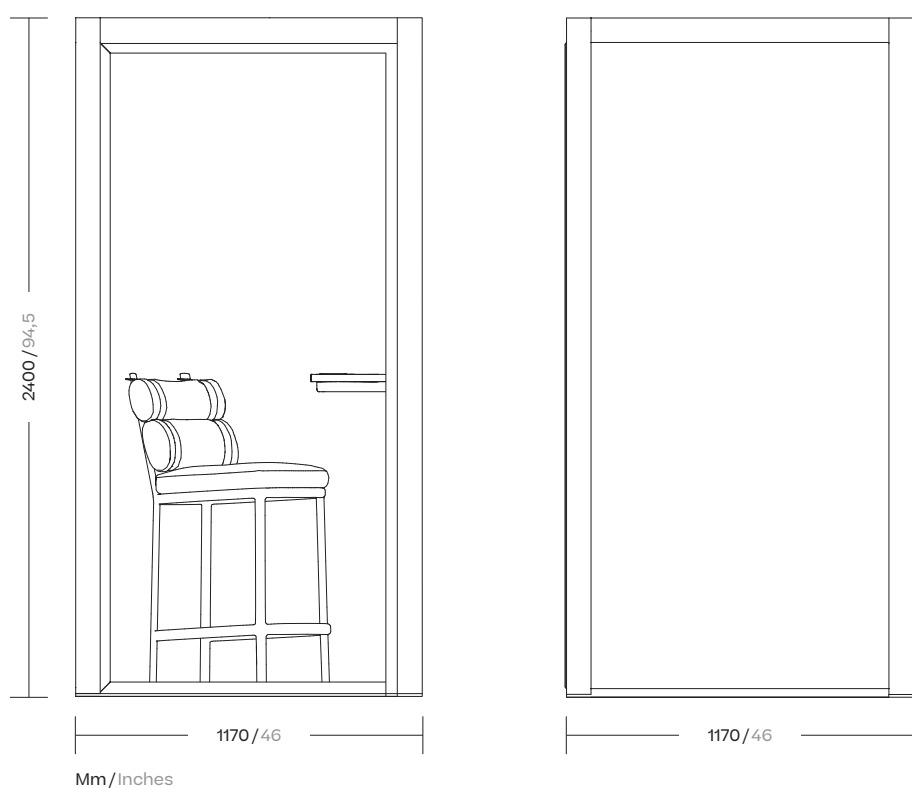

## Description

A phone booth with one seat. Ideal to join a call or video conference with your client, free from all distractions. The exceptional acoustics and physical comfort allow for better communication, as well as concentration.

## Specifications

- Single or double glazed wall system
- Pivot door
- Metal frame
- Acoustic panels
- Absorption system
- Fabric or glass
- Faced external wall
- Air ventilation system
- LED lighting
- PIR sensor

# Phonebooth S

Designer  
Kettal Studio

Collection  
Phonebooth

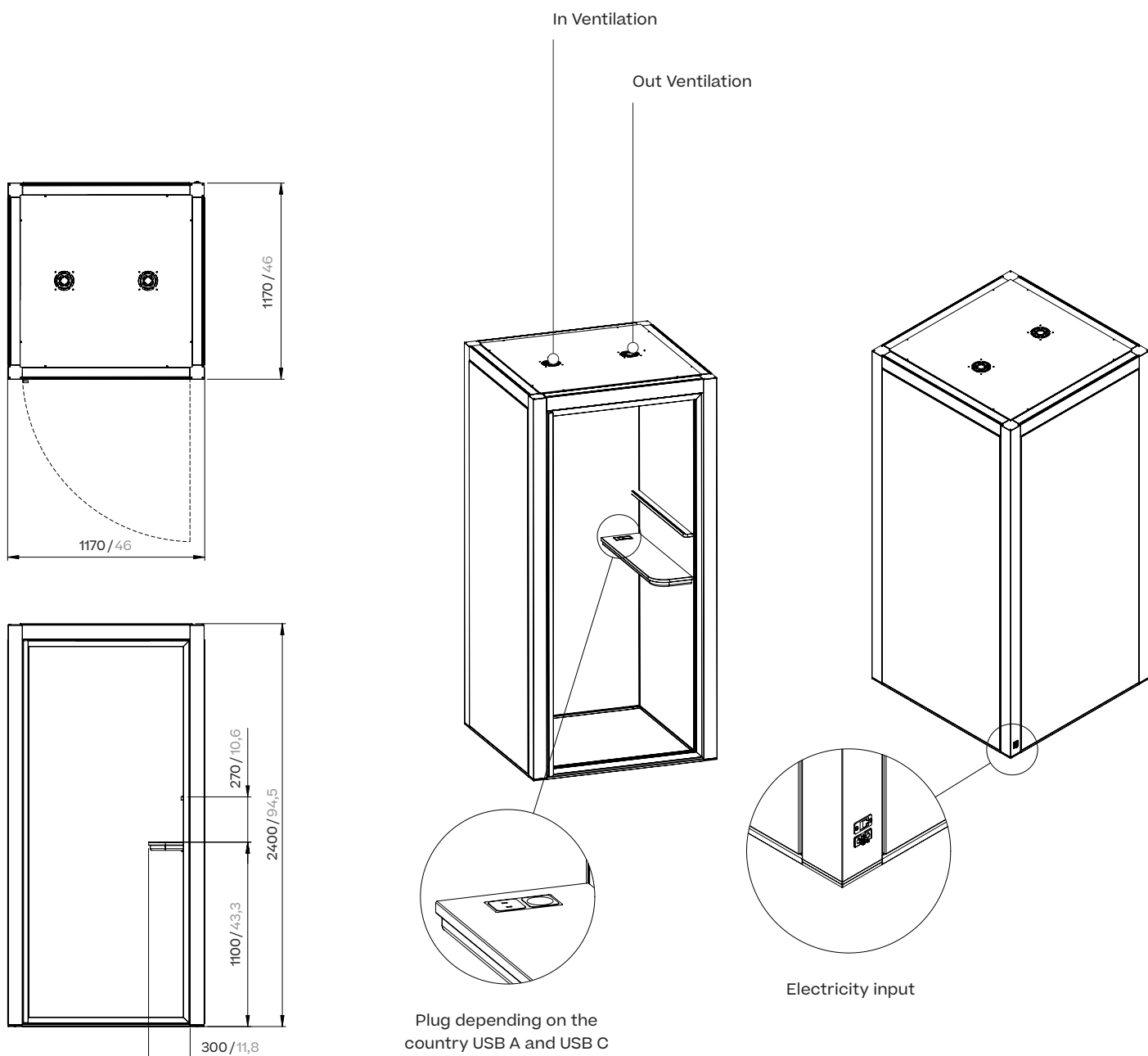

# Phonebooth S

Designer  
Kettal Studio

Collection  
Phonebooth



# Phonebooth S

Designer  
Kettal Studio

Collection  
Phonebooth

Version A



3 fabric sides

Version B



2 fabric sides & 1 back side glass



# Phonebooth L

Designer  
Kettal Studio

Collection  
Phonebooth

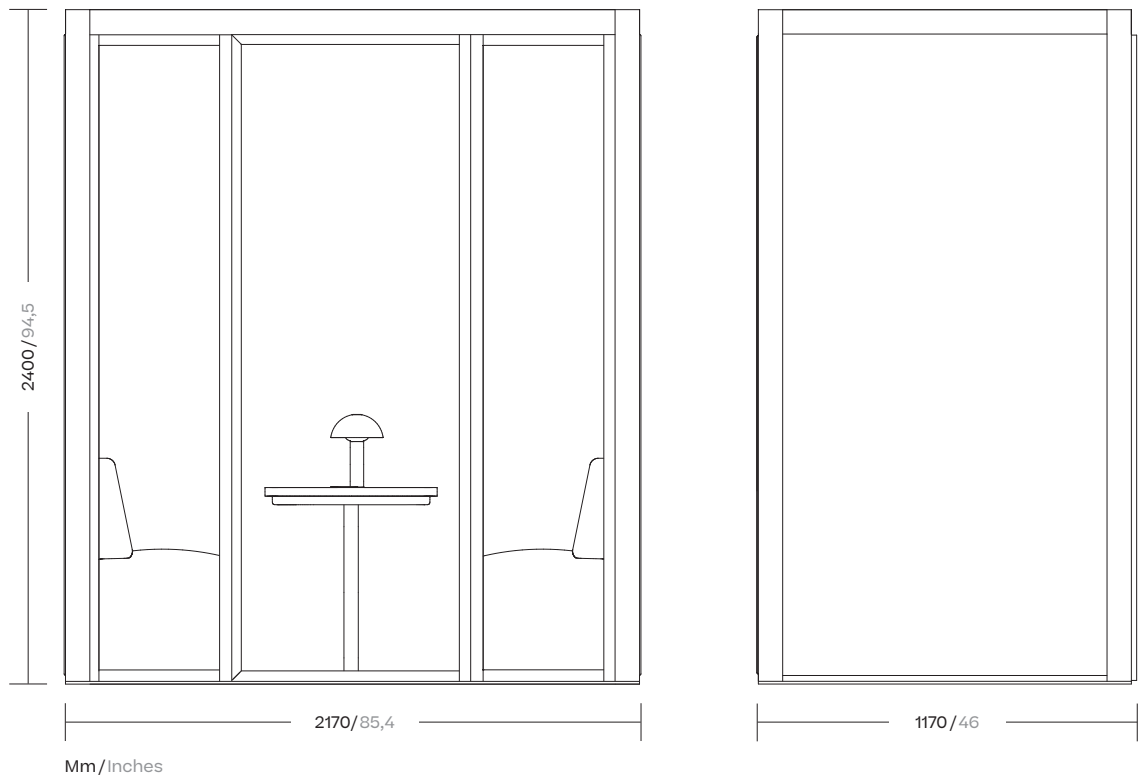

## Description

A phone booth with 2 seats. Convenient to sit down for one-on-one meetings in private. The exceptional acoustics and physical comfort allow for better communication, as well as concentration.

## Specifications

- Single or double glazed wall system
- Pivot door
- Metal frame
- Acoustic panels
- Absorption system
- Fabric or glass
- Faced external wall
- Air ventilation system
- LED lighting
- PIR sensor

# Phonebooth L

Designer  
Kettal Studio

Collection  
Phonebooth



# Phonebooth L

Designer  
Kettal Studio

Collection  
Phonebooth

Version A



Fabric in back side + Sofa O

Version B



Glass in back side + Sofa O

Version C



Fabric in back side + Bar Stool

Version D



Glass in back side + Bar Stool

# Phonebooth XL

Designer  
Kettal Studio

Collection  
Phonebooth

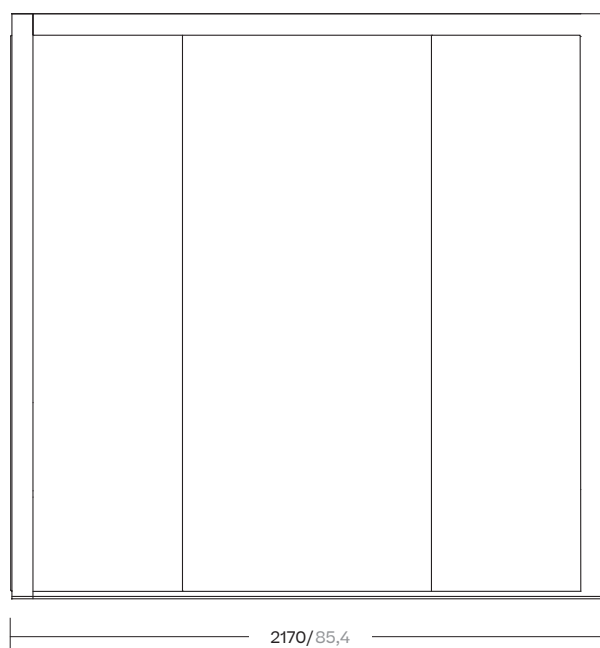
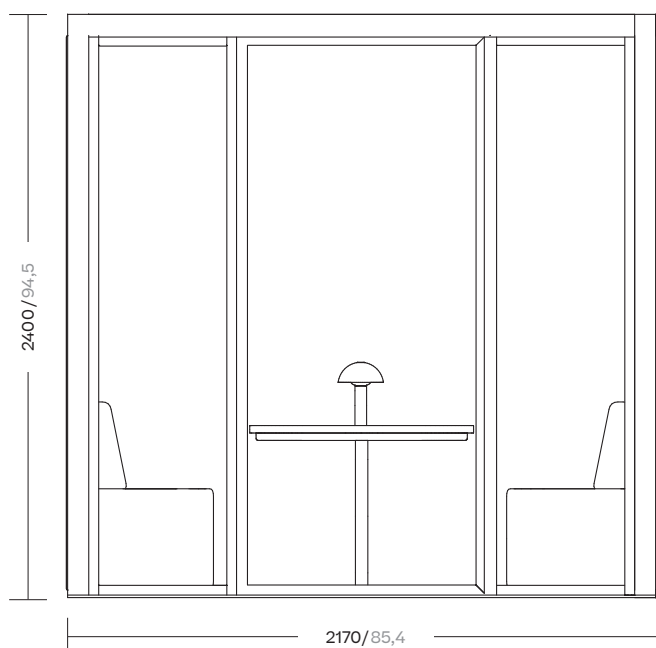

## Description

A Phone Booth with 4 seats. Ideal for meetings in spacious comfort and privacy. The exceptional acoustics and physical comfort allow for better communication, as well as concentration.

## Specifications

- Single or double glazed wall system
- Pivot door
- Metal frame
- Acoustic panels
- Absorption system
- Fabric or glass
- Faced external wall
- Air ventilation system
- LED lighting
- PIR sensor

# Phonebooth XL

Designer  
Kettal Studio

Collection  
Phonebooth



# Phonebooth XL

Designer  
Kettal Studio

Collection  
Phonebooth

Version A

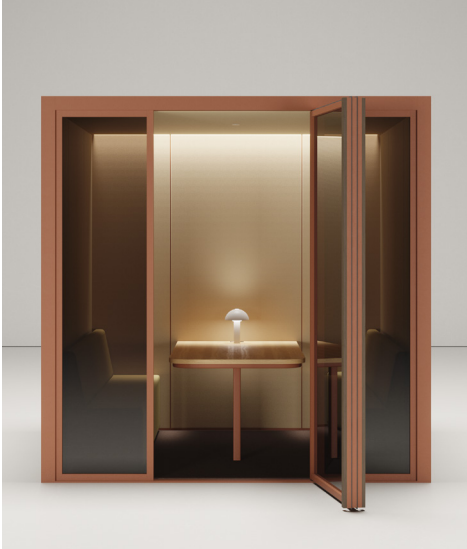

Fabric in back side + Sofa O

Version B

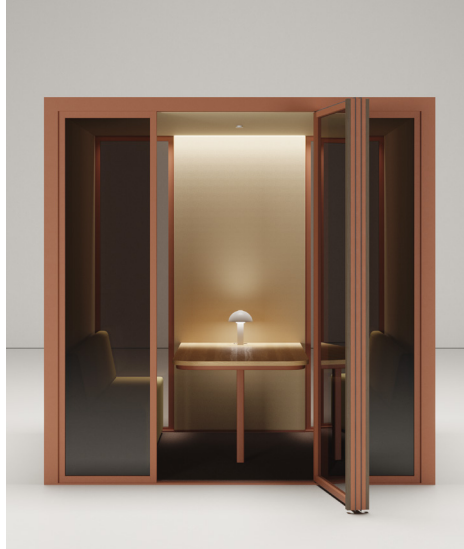

Glass in back side + Sofa O

Version C



Fabric in back side + Bar Stool

Version D



Glass in back side + Bar Stool

# Phonebooth, Technical specifications

**kettal**

## LED Track Curtain

---

A recessed lighting system equipped with an LED light source. Specially designed for wall-washer lighting, the LED Curtain incorporates lenses to provide optimum light distribution. The LED Curtain range is available in different lengths which means it can be adjusted to suit any space, while its compact size facilitates simple integration within the Phonebooth system.



4,7/1,8 



Cm/Inches





# Table mounted outlets

Technical specifications

Designer  
Kettal Studio

Collection  
Phonebooth

## Hardware

---

- Simple design
- Power Connections
- USB

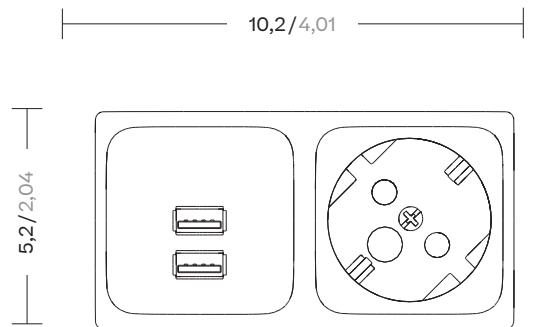

Phonebooth,  
Acoustic side panels

**kettal**

## Description

All our panels are tested to ensure they meet the required acoustic levels. We have tested some of the wall combinations to provide guidelines with regard to acoustic levels. Acoustic performance varies depending on the material selection for each wall.

The O glass version offers excellent acoustic performance, creating a comfortable and efficient working environment. It is based on 6+6 laminates with a soundproofing membrane to provide an impressive acoustic performance of up to 39dB. We also offer a range of solid wall options in fabric and wood. Many of these alternative wall options offer excellent acoustic performance properties. Our laminated panels not only provide additional acoustic performance, but also come in a range of colors. As a result, you can customize your Phonebooth to reflect your brand image or simply to create a bright office space. In addition, the eco-friendly panels reduce and control reverberated noise within the Pavilion, further enhancing the overall soundproofing performance.

## Key functions

- All materials meet the standard B-s2, d0.
- Anti memory acoustic foam
- Easy clean material
- Odor free and antimicrobial

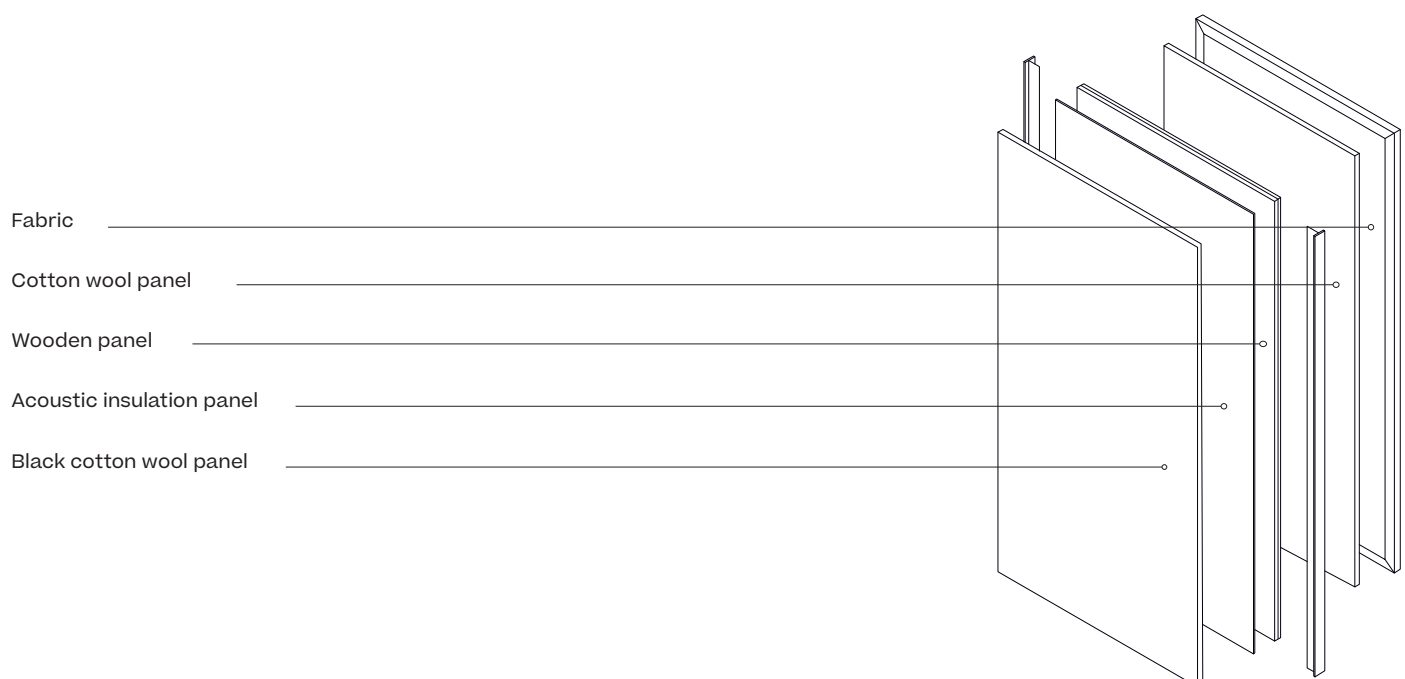

## Technical specifications



Ceiling Panel

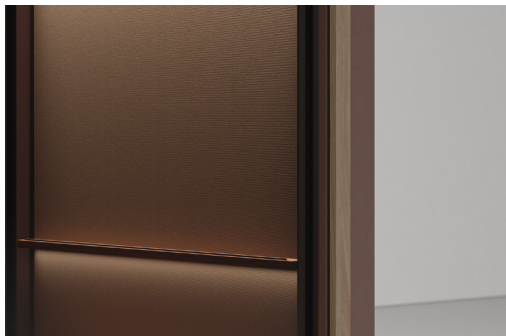
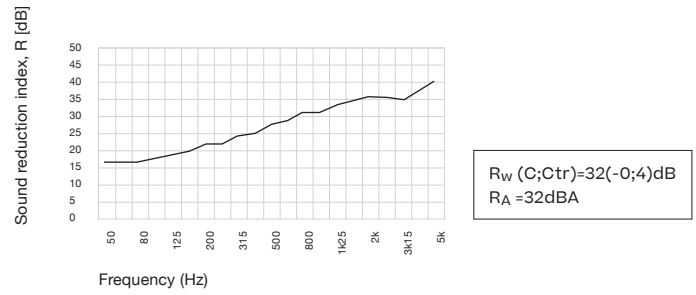

Plus Wall Panel

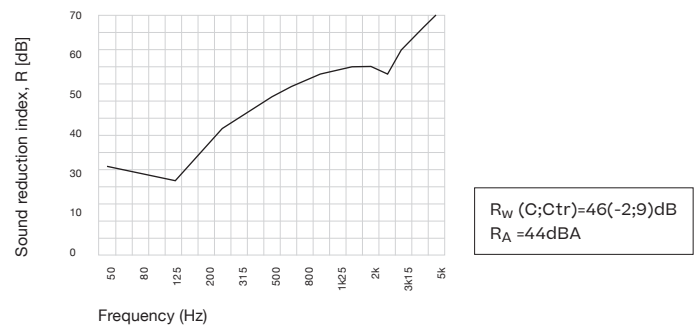

Plus Acoustic Glass & Glass door

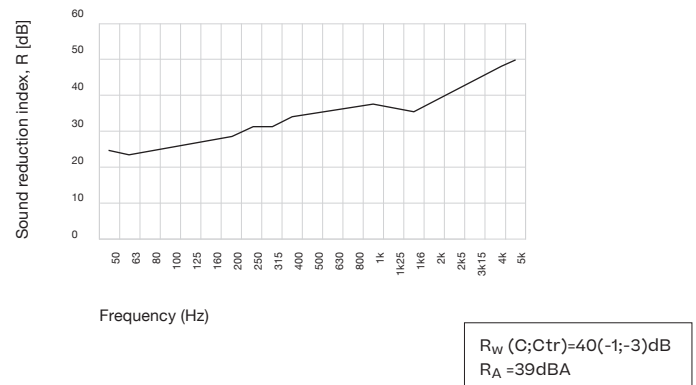

# Acoustic comfort

Acoustic side panels

Designer  
Kettal Studio

Collection  
Phonebooth

## Description

All our panels are tested to ensure they meet the required acoustic levels. We have tested some of the wall combinations to provide guidelines with regard to acoustic levels. Acoustic performance varies depending on the material selection for each wall.

The O glass version offers excellent acoustic performance, creating a comfortable and efficient working environment. It is based on 4+4 laminates with a soundproofing membrane to provide an impressive acoustic performance of up to 35dB. We also offer a range of solid wall options in fabric and wood. Many of these alternative wall options offer excellent acoustic performance properties. Our laminated panels not only provide additional acoustic performance, but also come in a range of colors. As a result, you can customize your Phonebooth to reflect your brand image or simply to create a bright office space. In addition, the eco-friendly panels reduce and control reverberated noise within the Pavilion, further enhancing the overall soundproofing performance.

## Key functions

- All materials meet the standard B-s2, d0.
- Anti memory acoustic foam
- Easy clean material
- Odor free and antimicrobial

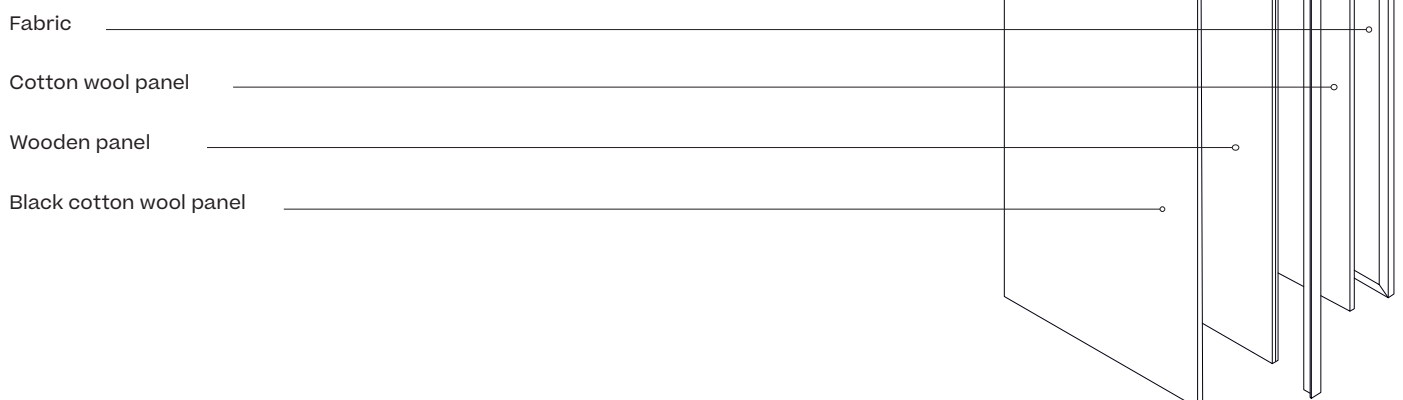

# Acoustic comfort

Acoustic side panels

Designer  
Kettal Studio

Collection  
Phonebooth

## Technical specifications



Ceiling Panel

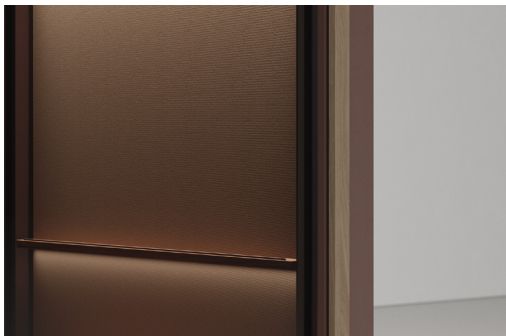
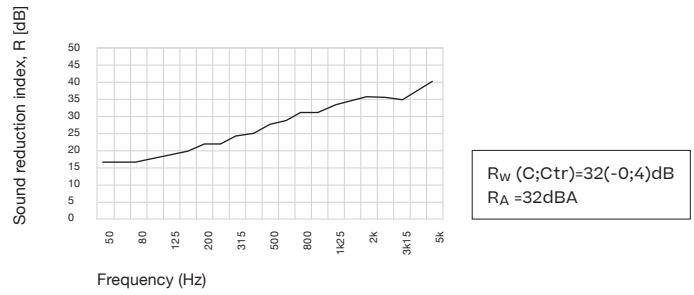

Comfort Wall Panel

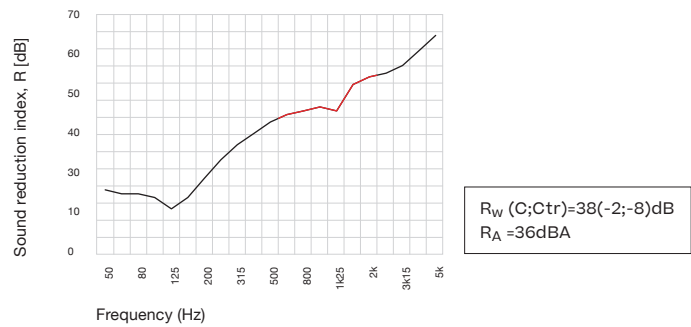

Comfort Acoustic Glass & Glass door

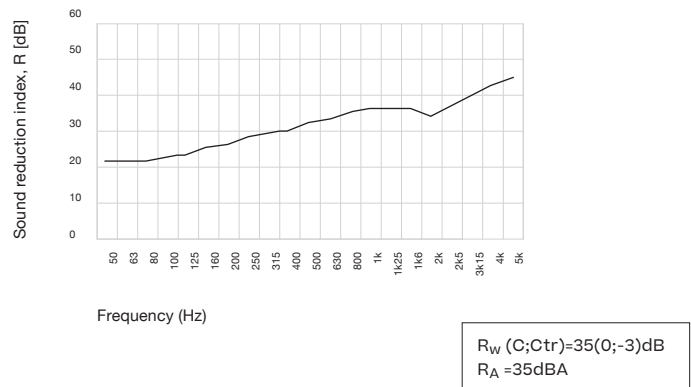

Phonebooth  
Aesthetics & materiality

**kettal**

## Structural Aluminium

Extruded and hollow profiles of this alloy will be used to build up the structures of each booth.

This is a light and ductile alloy, with great strength and magnificent finishing characteristics. It is ideal for works that require high quality and perfect finishes.

It has excellent corrosion resistance, similar to that of stainless steel. Follows the UN-EN-AW 10204 3-1 regulation.

Kettal uses 80% recycled aluminum in the extrusion of its profiles in order to reduce greenhouse gases, thus contributing to a more sustainable production of our customers' products.

## Chemical composition (UN-EN 10204 3-1 Regulation)

| %  | Min.<br>Máx. |
|----|--------------|
| Si | 0.30<br>0.60 |
| Fe | 0.10<br>0.30 |
| Cu | -<br>0.10    |
| Mn | -<br>0.10    |
| Mg | 0.35<br>0.60 |
| Cr | -<br>0.05    |
| Zn | -<br>0.15    |
| Ti | -<br>0.10    |



Recyclable



80%  
recycled



Local supplier

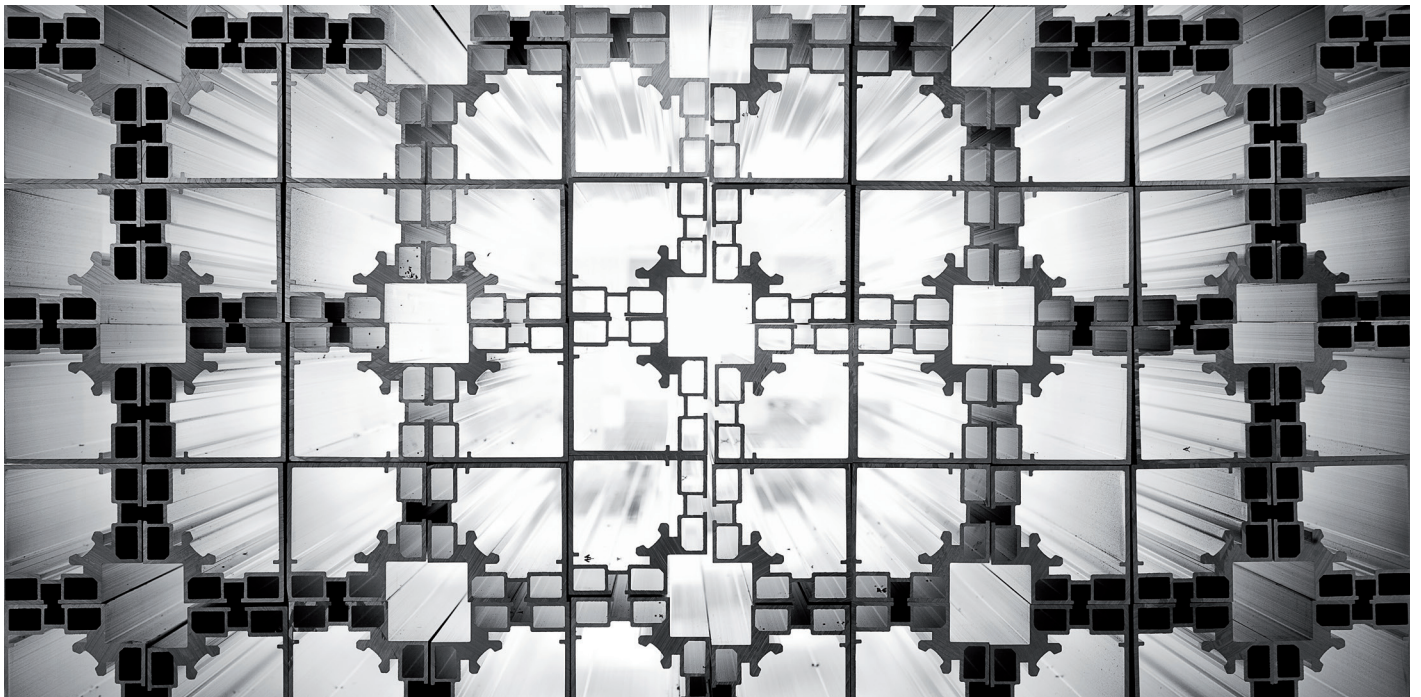



## Technical wood

The technical wood is one of the main components to create the acoustic lateral panel and ceiling. 10mm fire-fighter. Complies with E1 regulation

The environmental product declaration is in accordance with ISO 14025 and EN 15804.

Comply with standards EN 622- 1, EN 622-5 and EN 14322. They are considered reliable products used as raw material for the construction and furniture industry.

| Characteristics                 | Test                        | Units        |
|---------------------------------|-----------------------------|--------------|
| Density                         | EN 323                      | kg/m3        |
| Flexural strength               | EN 310                      | N/mm2        |
| Formaldehyde emission           | EN 717-1                    | ppm          |
| Reaction to fire                | EN 13501-1                  | Euroclase    |
| Absorption acoustic coefficient | UNE EN 13986:2006+A 1 :2015 | $\alpha$     |
| Acoustic insulation             | UNE EN 13986:2006+A 1 :2015 | db           |
| Biological durability           | UNE EN 335                  | Clase de uso |



Type 2  
From cradle to gate with options



Local supplier



Formaldehyde free



## Soundproof Safety Glass

6 mm / 1 PVB / 6 mm

Soundproof safety glass, consists of two or more glass sheets joined by one or more Polyvinyl Butiral (PVB) films,

Direct acoustic isolation 39 dB.

If a laminated glass is broken, the PVB film retains a large part of the glass fragments, that is, the residual strength and the maintenance of the glazing are kept in the same place until they are replaced.

These glasses filter 99% of the UV rays and contribute to extend the life of curtains, rugs, fabrics, objects, etc., which are exposed daily to natural light.

It offers protection against a need for security and complies with the requirements of current norms and regulations, both for homes, shops or offices.

In case of breakage, the fragments remain attached to the sheet.

## Chemical composition

|                                |           |
|--------------------------------|-----------|
| SiO <sub>2</sub>               | 69 - 74 % |
| Na <sub>2</sub> O              | 10 - 16 % |
| CaO                            | 5 - 14 %  |
| MgO                            | 0 - 6 %   |
| Al <sub>2</sub> O <sub>3</sub> | 0 - 3 %   |
| Others                         | 0 - 5 %   |



Belgian  
supplier



Soundproof  
safety glass



## Description

Terrain Coatings are designed for aluminum profile coatings used in architecture and for other substrates where maximum outdoor resistance is needed.

It is a powder coating formulated with polyester resins and free of TGIC, pigments and additives. They offer excellent exterior durability with very good gloss retention and color stability.

## Certificates



Class A2



Polymerization  
at 160°



Local supplier



# Materials

Aesthetics & Materiality











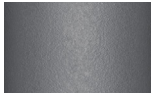
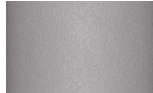
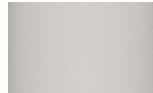
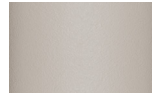













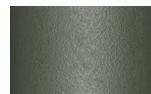

Designer  
Kettal Studio

Collection  
Phonebooth

## Technical specifications

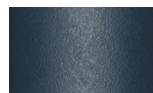
| Characteristics                 | Min.                          | Max.                          | Method     |
|---------------------------------|-------------------------------|-------------------------------|------------|
| Baking time / temperature       | 24 to 150 °C / 75,2 to 302 °F | 26 to 150 °C / 78,8 to 302 °F | Total time |
| Gloss at 60° angle              | 6                             | 9                             | ISO 2813   |
| Direct impact 12.5 mm           | 30                            |                               | ISO 2813   |
| Indirect impact 12.5 mm         | 30                            |                               | ISO 2813   |
| Cross-cut adhesion              | 0                             | 0                             | ISO 2813   |
| Erichsen Cupping test           | 5                             | 11                            | ISO 2813   |
| Bend test (Cylindrical Mandrel) |                               | 6                             | ISO 2813   |
| Avg. Particle size              | 50                            | 55                            | MALVERN    |
| Particle size % < 100 MICRONS   | 80                            | 95                            | MALVERN    |
| Particle size % < 50 MICRONS    | 50                            | 65                            | MALVERN    |
| Particle size % < 10 MICRONS    | 4                             | 8                             | MALVERN    |
| Delta E colour                  |                               | VISUAL                        | CIELAB     |
| General appearance              | Textured                      |                               | NIZI-001   |

## Colours

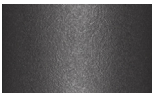
|  |   |   |   |   |  |   |   |
|--|---|---|---|---|--|---|---|
|  |  |  |  |  |  |  |  |
| Slate Stone<br>01C   | Mystic Smoke<br>02C   | Ash<br>03C  | Bone<br>04C   | Tuff<br>05C   | Wet Stone<br>06C   | Sand Dune<br>07C  | Dry Clay<br>08C   |
|  |  |  |  |  |  |  |  |
| Arabica<br>09C   | Sepia<br>19C  | Rose Canyon<br>16C  | Blossom<br>20C  | Ruby Dust<br>18C  | Sunset Glow<br>17C   | Terrarosa<br>15C  | Terracotta<br>14C   |
|  |  |  |  |  |  |  |  |
| Amber<br>13C   | Ginger Root<br>12C  | Desert Storm<br>11C   | African Savannah<br>10C   | Spring Meadow<br>28C  | Kombu<br>29C   | Forest Stream<br>27C  | Sea Moss<br>26C   |
|  |  |  |  |  |  |  |  |
| Glacier Ice<br>25C   | Polar Sky<br>24C  | Nightfall<br>23C  | Indigo<br>22C   | Wild Lupin<br>21C   | Galena<br>33C  | Bronze<br>30C   | Corten<br>31C   |
|  |   |   |   |   |  |  |   |
|  |   |   |   |   |  | Manganese<br>32C  |   |

## Kvadrat Relate Fabrics (FIRE RETARDANT)

---

Relate is a sophisticated twill weave upholstery textile designed by Patricia Urquiola made from Trevira CS, which has a soft hand resembling natural fibres.

The versatile palette for Relate comprises 35 colourways and expresses confident colour combinations by combining warm notes with closely related nuances.

## Care instructions

---



## Technical specifications

|                           |   |
|---------------------------|---|
| Composition               | 100% Trevira  |
| Width                     | Approx. 140 cm  |
| Weight per m <sup>2</sup> | Approx. 328/m <sup>2</sup>  |
| Fire test                 | AS/NZS 3837 class 2, BS 5852 Crib 5, BS 5852 part 1 with treatment, DIN 4102 B1, EN 1021-1/2, IMO FTP Code 2010 Part 8, NF D 60 013, NF P 92 503 M1, NFPA 701, SN 198 898 5.2, UNI 9177 Classe 1, US 1 Cal. Bull. 117-2013, ÖNORM B1/Q1 |
| Lightfastness             | 5-7 (ISO 1-8)   |
| Shrinking                 | App 2%  |
| Abrasion Martindale       | 80.000 Martindale   |
| Wash load                 | Half  |
| Pilling                   | 4-5 (ISO 1-5)   |
| Colour                    | Slight differences may occur  |
| Produced in environment   | Greenguard Certification <a href="http://www.greenguard.org">www.greenguard.org</a>   |

## Colours

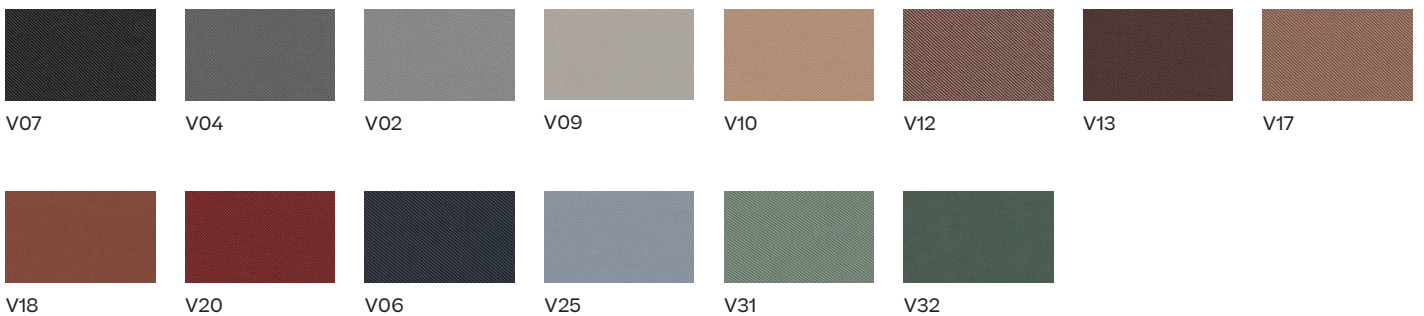

# Materials

Aesthetics & Materiality

Designer  
Kettal Studio

Collection  
Phonebooth

## Terrain Fabrics (NOT FIRE RETARDANT)

---

This is a range of premium fabrics for indoor and outdoor furniture.

The hydrophobic technology applied works by impeding the liquids that permeate the fabric, forcing them to roll out of the fabric in the form of drops. The fabric protection that brings out the liquids allows for drops of water and oil to be eliminated during normal washing without leaving any traces.

Solution-dyed acrylic; is dyed before thread is created. A liquid acrylic solution is mixed with dye and then formed into a fiber and spun on thread.

Composed of different 3 shades of unique colors.



Anti-mould



Water repellent

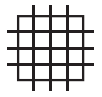

Thermal welding



UV-Resistant



NFPA 260



CAL 117

## Care instructions

---

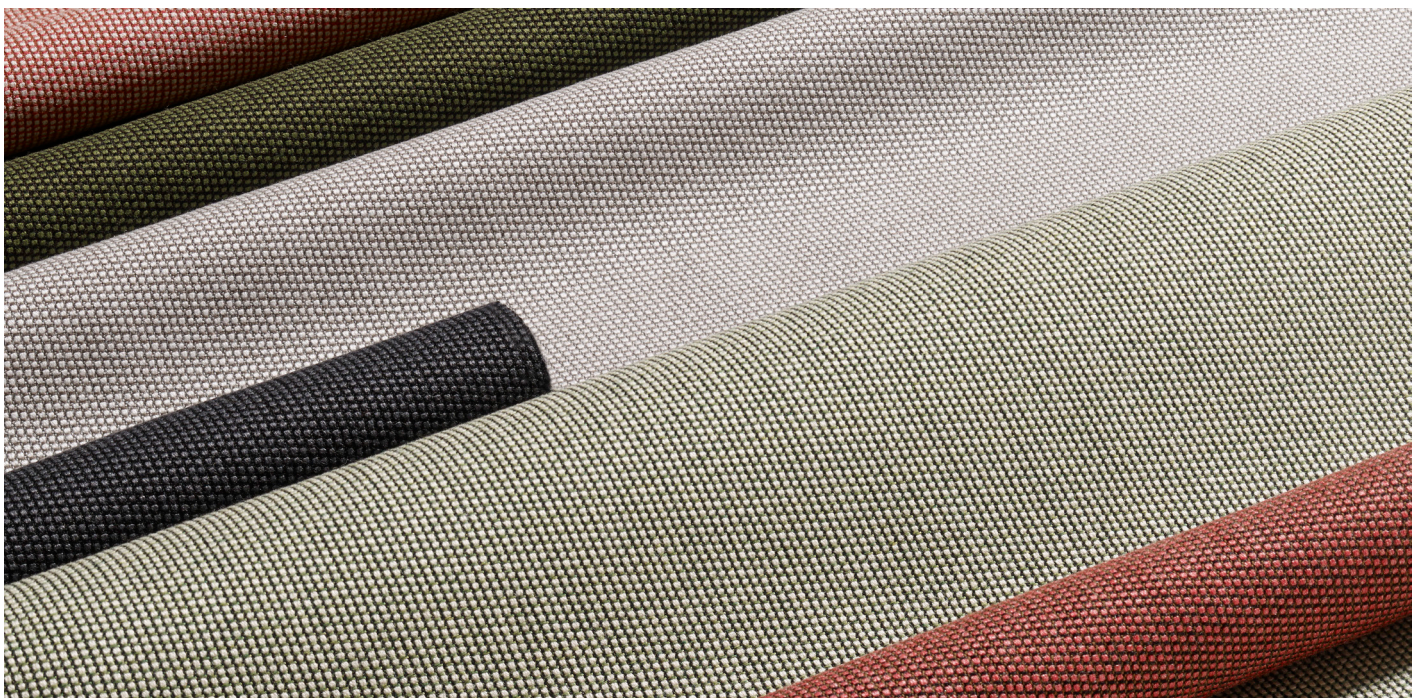

## Technical specifications

|   |                    |             |
|---|--------------------|-------------|
| Material                                      | 100% acrylic, dyed |             |
| Grammage                                      | 400 g/m2           | ISO 2286-2  |
| Resistant to superficial wetting              | 100 ISO 24920      | ISO 24920   |
| Oil resistance                                | 6                  | AATCC 118   |
| Colour fastness to artificial weathering      | 7-8 blue scale (8) | ISO 105-B04 |
| Colour fastness to light                      | 7-8 blue scale (8) | ISO 105-B02 |
| Title warp and weft                           | Nm 2/34 Nm 6/34    |             |
| Tensile strength, warp                        | 180 daN/5 cm       | ISO 13934   |
| Tensile strength, weft                        | 240 daN/5 cm       | ISO 13934   |
| Tear resistance, warp                         | 21.0 daN           | ISO 4674-1  |
| Tear resistance, weft                         | 29.0 daN           | ISO 4674-1  |
| Abrasion resistance (Martindale)              | 30,000 cycles      | ISO 12947-2 |
| Abrasion resistance (Wyzenbeek)               | 15,000 double rubs | ASTM D4157  |
| Cigarette ignition classification             | Class 1            | NFPA 260    |
| Material resistance to ignition without flame | Pass               | CA TB 117   |

## Colours

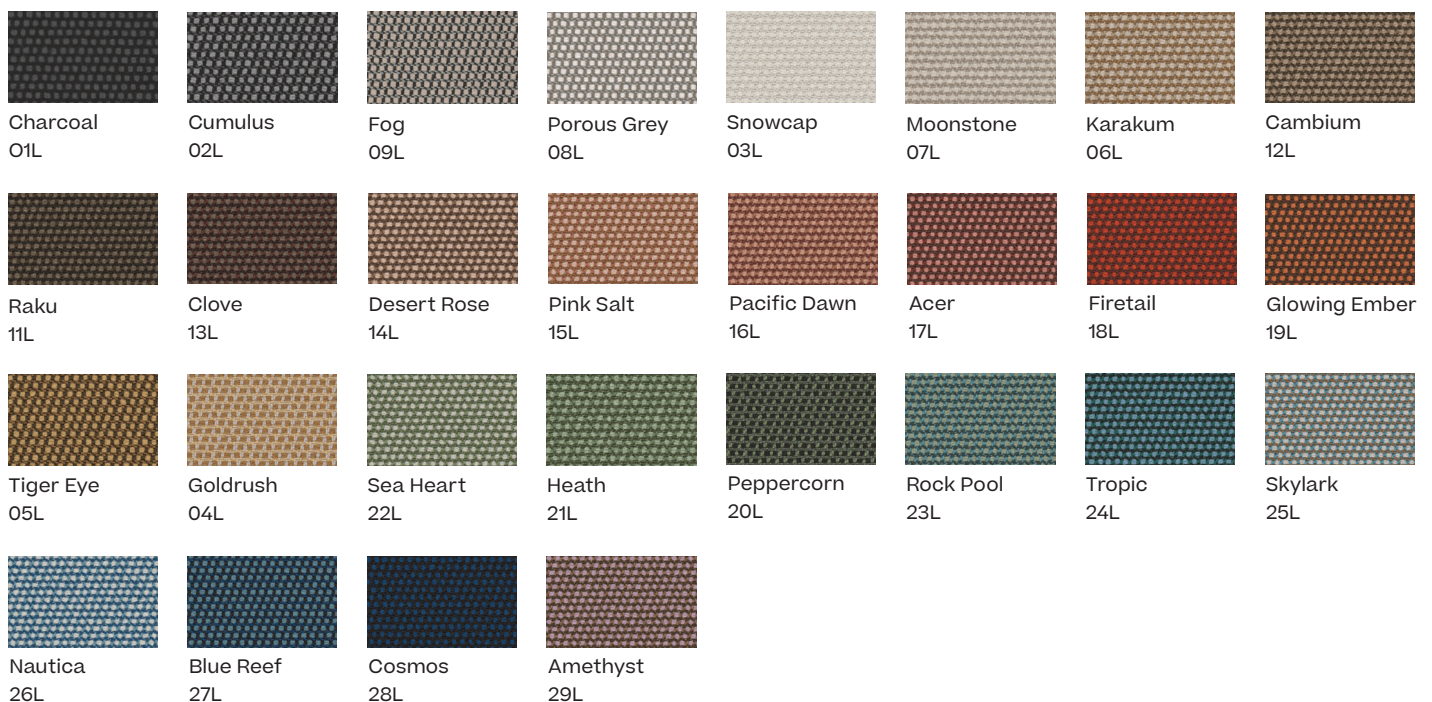



## Tonale Boucle (NOT FIRE RETARDANT)

---

Like Terrain Elements, Tonale Boucle is a 100% fire-resistant outdoor Acrylic fabric. Designed by Vincent Van Duysen exclusively for the Giro collection cushions.

## Care instructions

---

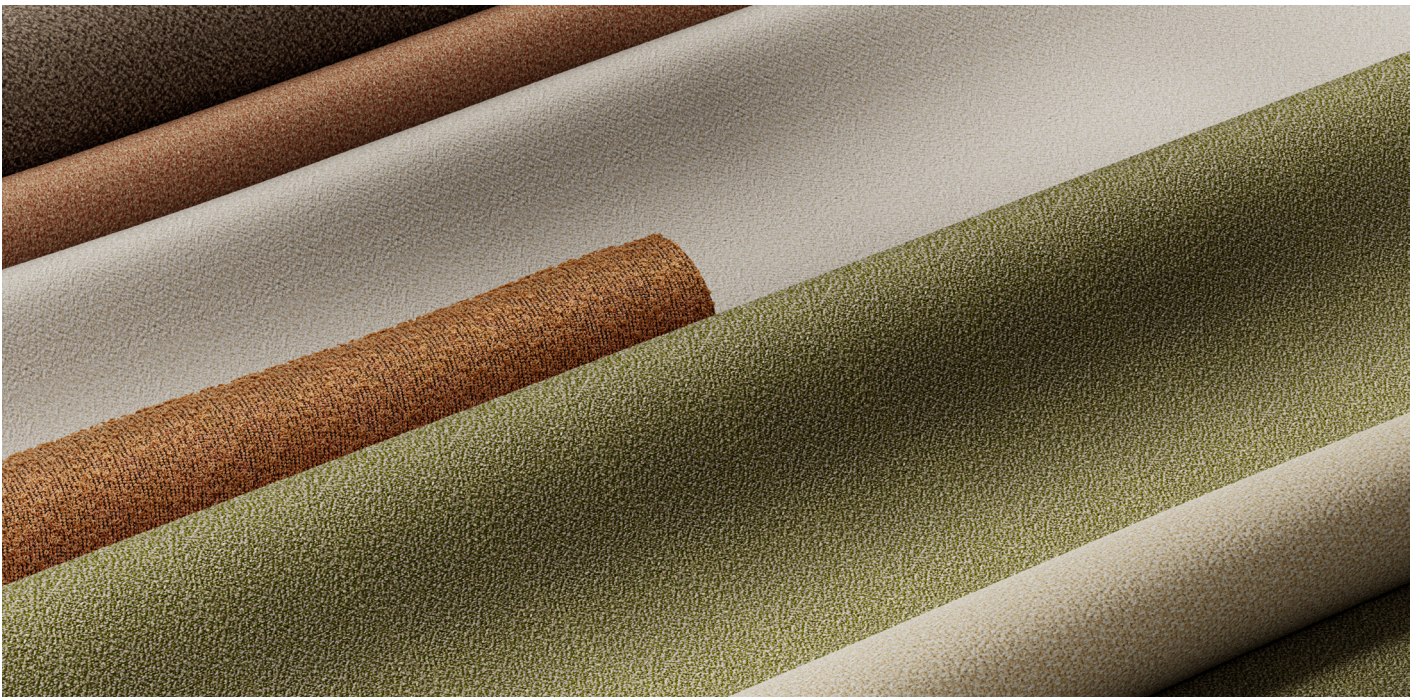

## Technical specifications

|   |                                |             |
|---|--------------------------------|-------------|
| Composition                                   | 60% Dyed Acrylic 40% Polyester |             |
| Grammage (g/m <sup>2</sup> )                  | 515                            | ISO 2286-2  |
| Resistant to superficial wetting              | 100 ISO 24920                  | ISO 24920   |
| Oil resistance                                | 6                              | AATOC 118   |
| Colour fastness to artificial weathering      | 7-8 blue scale (8)             | ISO 105-B04 |
| Colour fastness to light                      | 7-8 blue scale (8)             | ISO 105-B02 |
| Title warp and weft (Nm)                      | 2/34 6/34                      |             |
| Tensile strength, warp (daN/5cm)              | 180                            | ISO 13934   |
| Tensile strength, weft (daN/5cm)              | 240                            | ISO 13934   |
| Tear resistance, warp (daN)                   | 21                             | ISO 4674-1  |
| Tear resistance, weft (daN)                   | 29                             | ISO 4674-1  |
| Abrasion resistance (Martindale)              | 30,000 cycles                  | ISO 12947-2 |
| Abrasion resistance (Wyzenbeek)               | 15,000 double rubs             | ASTM D4157  |
| Cigarette ignition classification             | Class 1                        | NFPA 260    |
| Material resistance to ignition without flame | Pass                           | CA TB 117   |

## Colours



White Poppy  
81L-81T



Sesame  
82L-82T

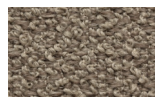

Anise  
83L-83T

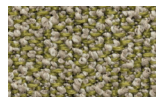

Dill  
84L-84T



Allspice Jamaica  
85L-85T



Bird's Foot  
86L-86T

## Tonale Lino (NOT FIRE RETARDANT)

---

Like Terrain Elements, Tonale Lino is a 100% fire-resistant outdoor Acrylic fabric. Designed by Vincent Van Duysen exclusively for the Giro collection cushions.

## Care instructions

---

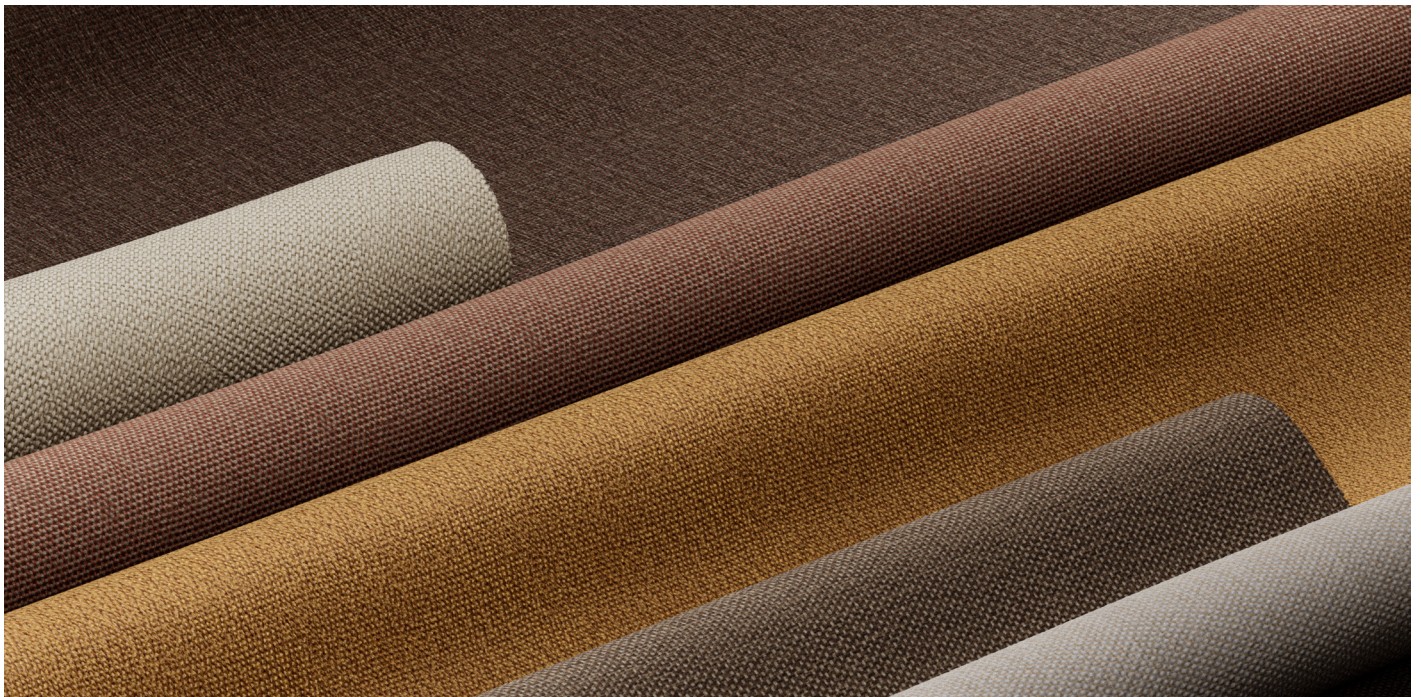

## Technical specifications

|   |                       |             |
|---|-----------------------|-------------|
| Composition                                   | 100% Solution Acrylic |             |
| Grammage (g/m <sup>2</sup> )                  | 500                   | ISO 2286-2  |
| Resistant to superficial wetting              | 100 ISO 24920         | ISO 24920   |
| Oil resistance                                | 6                     | AATOC 118   |
| Colour fastness to artificial weathering      | 7-8 blue scale (8)    | ISO 105-B04 |
| Colour fastness to light                      | 7-8 blue scale (8)    | ISO 105-B02 |
| Title warp and weft (Nm)                      | 2/34 6/34             |             |
| Tensile strength, warp (daN/5cm)              | 180                   | ISO 13934   |
| Tensile strength, weft (daN/5cm)              | 240                   | ISO 13934   |
| Tear resistance, warp (daN)                   | 21                    | ISO 4674-1  |
| Tear resistance, weft (daN)                   | 29                    | ISO 4674-1  |
| Abrasion resistance (Martindale)              | 30,000 cycles         | ISO 12947-2 |
| Abrasion resistance (Wyzenbeek)               | 15,000 double rubs    | ASTM D4157  |
| Cigarette ignition classification             | Class 1               | NFPA 260    |
| Material resistance to ignition without flame | Pass                  | CA TB 117   |

## Colours

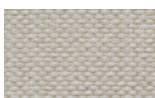

White Chia  
61L-61T

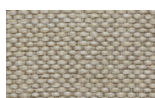

Fennel  
62L-62T

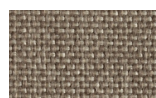

Elwendia  
63L-63T

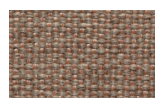

Brown Mustard  
64L-64T

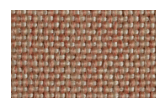

Kampot  
65L-65T



Fenugreek  
66L-66T

## Recycled Cotton Wool

1. Ecological Product. Bio-sustainable. 80% recycled and 100% recyclable.
2. Safe in its installation: It does not cause discomfort or itching as it is based on natural fibers.
3. Elastic product. Does not break when folding. Its modulus of elasticity compared to rock wool is: 7 times better.

It does not promote combustion. Fire classification: M1 Certified 09/32300075 and 76 + according to UNE 23721-90, EN 13501-1.

| Frequency | Rockwool 4cm | Cotton 3cm |
|-----------|--------------|------------|
| 100       | 40,7         | 43,8       |
| 200       | 43,8         | 42         |
| 250       | 46,8         | 33,2       |
| 400       | 47,2         | 46,8       |
| 500       | 47,8         | 53,3       |
| 1000      | 54,4         | 54         |
| 1250      | 55,6         | 56,8       |
| 1600      | 56,6         | 57,5       |
| 2000      | 59,3         | 60,1       |
| 2500      | 61           | 61,2       |
| 3150      | 64,3         | 66         |
| 4000      | 66,1         | 68         |
| GLOBAL    | 53 dBA       | 54,6 dBA   |



Type 2  
From cradle to gate with options



Local supplier



Recyclable



## Soundproofing Membrane

---

High-density, polymer-based, asphalt-free synthetic soundproofing membrane.

## Note

---

No substances including in the LIST OF PROHIBITED SUBSTANCES in CRADLE TO CRADLE CERTIFIED PRODUCTS PROGRAM are used in the manufacturing of the product range Soundproofing Membrane so those substances are not expected to be on the final product.

## Restricted Substances (REACH Annex 17)"

---

The item(s) stated within section "2" of this declaration satisfy the requirements that are defined in Title VIII of Regulation (EC) No. 1907/2006 (REACH regulation ), including the restrictions listed in Annex 17 of REACH.

Link: <https://echa.europa.eu/substances-restricted-under-reach>



Local supplier

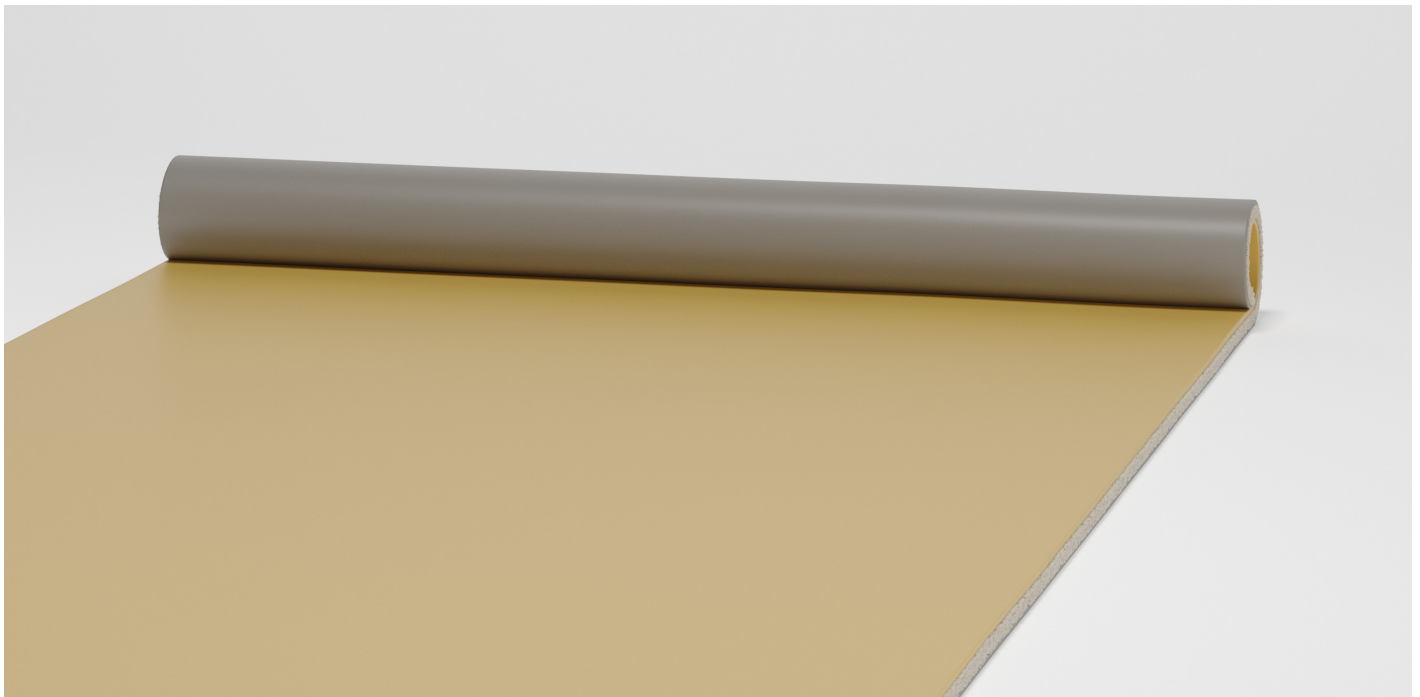

## Soundproofing Membrane

| Characteristics                  | Testing method    | Tecsoundsy | Units             |
|----------------------------------|-------------------|------------|-------------------|
| Density                          | -                 | 2.010      | kg/m <sup>3</sup> |
| Tensile strength                 | NT-67             | >30        | N/50mm            |
| Elongation                       | NT-67             | >500       | %                 |
| Fold                             | EN 1109           | -20        | °C                |
| Fire classification              | UNE-EN 13501-1    | Bs2d0      | -                 |
| Resistance factor to water steam | UNE-EN 1931 met B | μ>1806     | -                 |
| Water absorption (24h at 23°C)   | 1S062 met 1 NT74  | 0,003      | %                 |
| Shore A hardness                 | NT74              | 30±10      |                   |

| Regulation or protocol   | Conclusion  | Version of regulation of protocol  |
|--------------------------|---|--|
| French VOC Regulation    |  | Regulation of March and April 2011 (DEVL1101903D and DEVL1104875A)                                 |
| French CMR components    | Pass  | Regulation of March and April 2011 (DEVL1101903D and DEVL1104875A)                                 |
| AgBB/ABG                 | Pass  | Anforderungen an bauliche Anlagen bezüglich des Gesundheitsschutzes (ABG), Entwurf 31.08.2017      |
| Belgian Regulation       | Pass  | Royal decree of May 2015 (C-2014/24239)  |
| Indoor Air Comfort®      | Pass  | Indoor Air Comfort 6.0 of February 2017  |
| Indoor Air Comfort GOLD® | Pass  | Indoor Air Comfort GOLD 6.0 of February 2017   |
| Blue Angel (RAL UZ 132)  | Fail  | Low-Emission Thermal Insulation Material and Suspended Ceilings for Use in Buildings, October 2010 |
| BREEAM International     | Compliant   | GN22 v2.2 (August 2017): BREEAM Recognised Schemes for VOC Emissions from Building Products        |
| LEED v4 (outside U.S.)   | Compliant   | LEED v4 for Building Design and Construction (April 2015)  |

Phonebooth  
Technical data

**kettal**



## Power

---

Voltage Input: 100-240VAC (single-phase)  
Frequency Input: 50-60Hz  
Available system power: 16A (The electrical system is designed to support up to the right power)  
NETWORK line – RJ45 POE+  
Outlets support up to a total of 10A.

## Power connection

### Connection through one side of a column



Illustration 2 - Power and data connection through column side

#### When:

If the client does not have a raised floor and needs a surface-laid connection to the pavilion, the client must select this type of connection for the room.

#### How:

The column selected as “power supply and data input” will have a (male) surface connector.

The client must provide a power line up to that point.

To make the connection, Kettal provides a connector with a selected country plug to plug directly into the office socket.

There are two different levels of control:

## Sensor - STD format

---

Operation through presence sensor:  
When the user enters, the lighting and ventilation are turned on. When the user leaves, after 15 minutes, both the lighting and the ventilation are turned off.

## Sensor + Dimmer (Optional)

---

Operation through presence sensor and regulation (lighting) through pushbutton:  
When the user enters, the lighting and ventilation are turned on. Through a button it is possible to regulate the lighting (ceiling only). When the user leaves, after 15 minutes, both the lighting and the ventilation are turned off.

The Pavilion system allows 4 project layers depending on what the client prefers:

### A. Standard

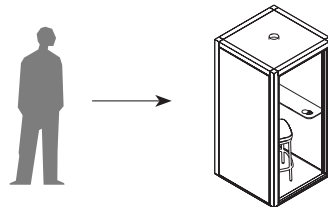

Phone Booth STD (with Sensor or Sensor + Dimmer). It is not connected to any control / management system.

### B. Hub Basic — Control

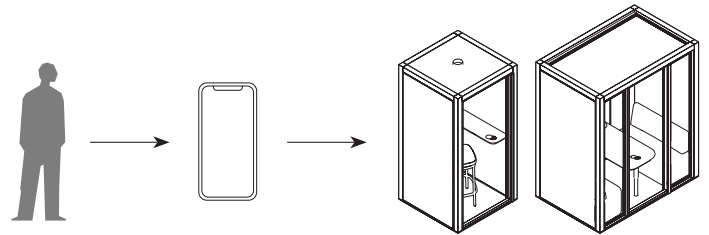

Allows the connection of each Phone Booth and Pavilion O to a Management Software for the client.

This is achieved through a HUB (which is installed in the customer's building), which must be connected to the network and which interconnects all rooms and Phone Booths.



Energy saving and space utilization



Response to electricity demand



Timelines



Scene control



Lighting control



Alerts

## How to determine the number of Hubs per project

The number of Hubs per project should be studied based on the layout of the rooms and the project based on the following product specifications.

It is necessary to connect to the customer's network through the RJ45 connection provided by the Hub.

All wireless devices to be associated with the wireless hub must be within 22 m (71 ft) of the wireless hub and must be on the same floor as the hub.

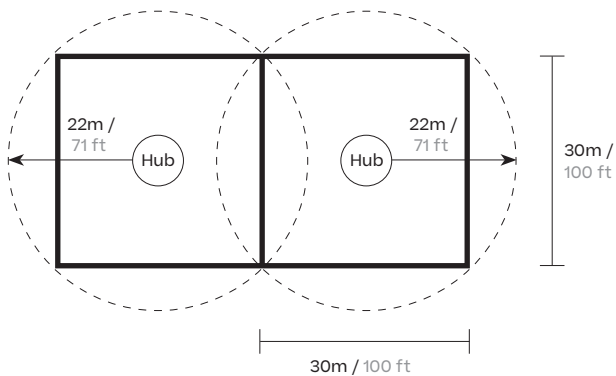

## C. Hub Server Pro — Control + Management

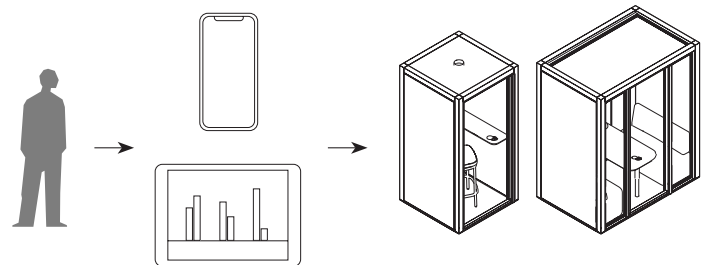

Allows the connection of each Phone Booth and Pavilion O to a Management Software for the client.

This is achieved through a HUB (which is installed in the customer's building), which must be connected to the network and which interconnects all rooms and Phone Booths. In addition, a server must be installed to be able to manage all the data and activate the system's functionalities:

**Intuitive control:** See status, control lights and optimize your building quickly and efficiently with a graphical plan.

**Space optimization:** Improve building layout based on actual occupancy and usage information.

**Save energy** with a specific goal thanks to energy reports.

This project layer allows for much greater control and visualization of data.

## D. Hub Bacnet — Bacnet Integration

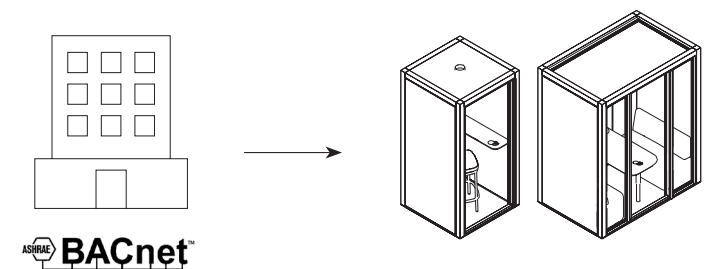

Allows the connection of each Phone Booth and Pavilion O to the building's BMS (Building Management System) system through the Bacnet IP protocol.

This is achieved through a Bacnet licensed Hub (which is installed in the customer's building), which must be connected to the network and which interconnects all rooms and Phone Booths.

## System's basic information

---

Operation through presence sensor:  
When the user enters, the lighting and ventilation are turned on. When the user leaves, after 15 minutes, both the lighting and the ventilation are turned off.

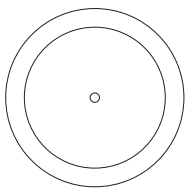

Wireless hub



- Response to demand
- Bacnet integration
- API integration

## Wireless controls and flexible sensors

---

- Remote controls
- Presence and daylight sensors
- Lighting controllers
- Home appliance charge controllers
- Integrated luminaire sensors and control

## Easy to use Software

---

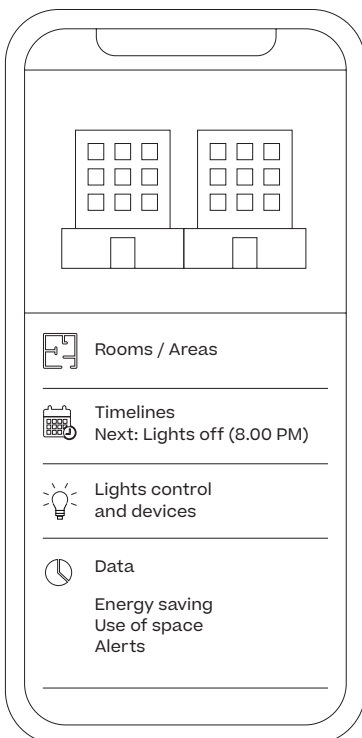

## Communication protocols

---



Communicate by RF with control components



Communicate over WiFi with smart devices



Communicate via Ethernet cable to the hub

# Security system

Technical data

Designer  
Kettal Studio

Collection  
Phonebooth

## Safety by design

---

1. Isolated wired or wireless architecture that strictly limits the ability of the hub's Wi-Fi to be used to access the corporate network to obtain confidential information.
2. Distributed security architecture: each hub has its own keys.
3. NIST-recommended best practices for password security, including tampering with and using Scrypt.
4. AES 128 bit encryption for network communications.
5. HTTPS protocol (TLS 1.2) to secure connections to the hub in the wired network.
6. WPA2 technology to ensure connections to the hub in the Wi-Fi network.

## Third party validation

---

1. Various external experts involved during the design process.
2. Penetration tests carried out by third parties to identify and correct potential vulnerabilities before installation.

## Monitoring and continuous improvements

---

A dedicated security team is used to constantly monitor potential threats and, when required, submit security patches to update installed systems.

## Permanent support

---

1. IT implementation guidelines
2. Guidance from our world-class 24/7 technical support organization with IT expertise, throughout the product lifecycle